

QUICK REFERENCE GUIDE

altronic
SaveAir ELECTRONIC
AIR START SYSTEM

TIPS AND HINTS TO ASSIST WITH INSTALLATION AND/OR OPERATION

6/22/21

Overview

The **Saveair Electronic Air Start System** replaces the existing OEM or pneumatic air distributor system with a solid state microprocessor-based control. This virtually eliminates all of the mechanical air-start related components and introduces significant operational advantages including a reduction in the required starting air and the elimination of starting dead spots.

SOLENOID INSTALLATION

Please note that the **24vdc** solenoids (PN#690-017-1) used in the **SaveAir System** are directional solenoids, therefore they must be installed accordingly. Based on installation issues, Altronic recommends that an air filter (PN#615-007) be installed on both the upstream and downstream side of the solenoids (FIG. 1).

This guide is provided to both clarify and add information to the current Operating Manual SA OM 5-05. This manual can be found on the Altronic website at: www.altronic-llc.com.

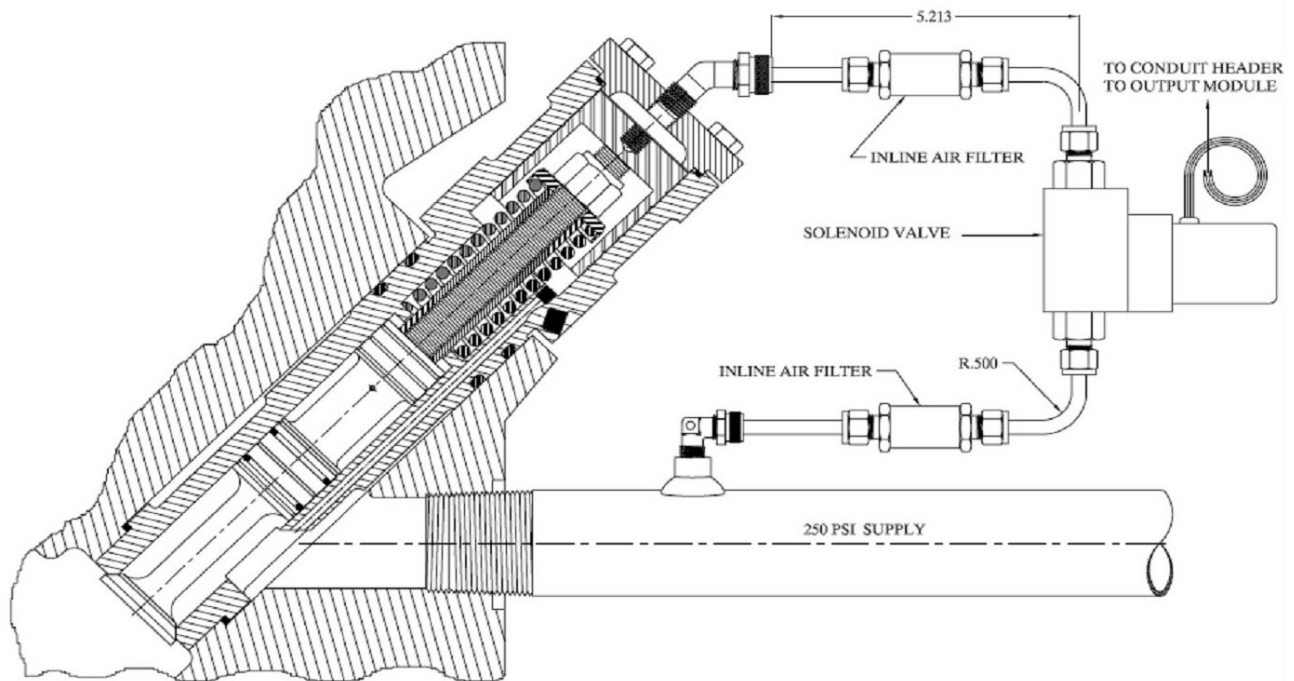

FIG. 1

QUICK REFERENCE GUIDE

A review of **SaveAir** installations has shown that, in some cases, the OEM air-in-head valves are in need of a rebuild, and that air leaks past the internal seals. This leaking air should be exhausted through the exhaust port of the solenoid, but often the leak is so large that the small solenoid exhaust port cannot accommodate it and pressure builds up. Once the pressure builds it starts to push the main air valve open, allowing air intended for starting to leak into the combustion cylinder. Since this is not acceptable the customer has two choices. The first is to rebuild the air-in-head valves, which is the best choice, but is often expensive and requires a long lead time. The second choice is to add a shuttle valve (example: **Ruelco PN#1702-S**) or a dual-exhaust port solenoid; either will allow more air to be exhausted. These shuttle valves are designed to rapidly bleed control pressures and have worked well in many **SaveAir** installations.

CLARK INSTALLATIONS (and any other engine manufacturers that do not have built-in air-in-head high pressure valves)

The **691-018-1 Altronic Relay Valve** replaces the OEM mechanical valves used to switch the high pressure air to the top of each power cylinder. One relay valve is needed for every mechanical valve removed. The Clark engines have a mechanical air start valve that must be cut off and reinstalled (**FIG. 2**). Cutting **1"** off these valves prevents them from contacting the camshaft lobes. These valves can be all-steel as shown, or have nylon or brass ends.

On the **Clark TCV**, the valve is removed entirely and a plate and gaskets are inserted between the air-valve box and the crankcase (**FIG. 3**).



FIG. 2

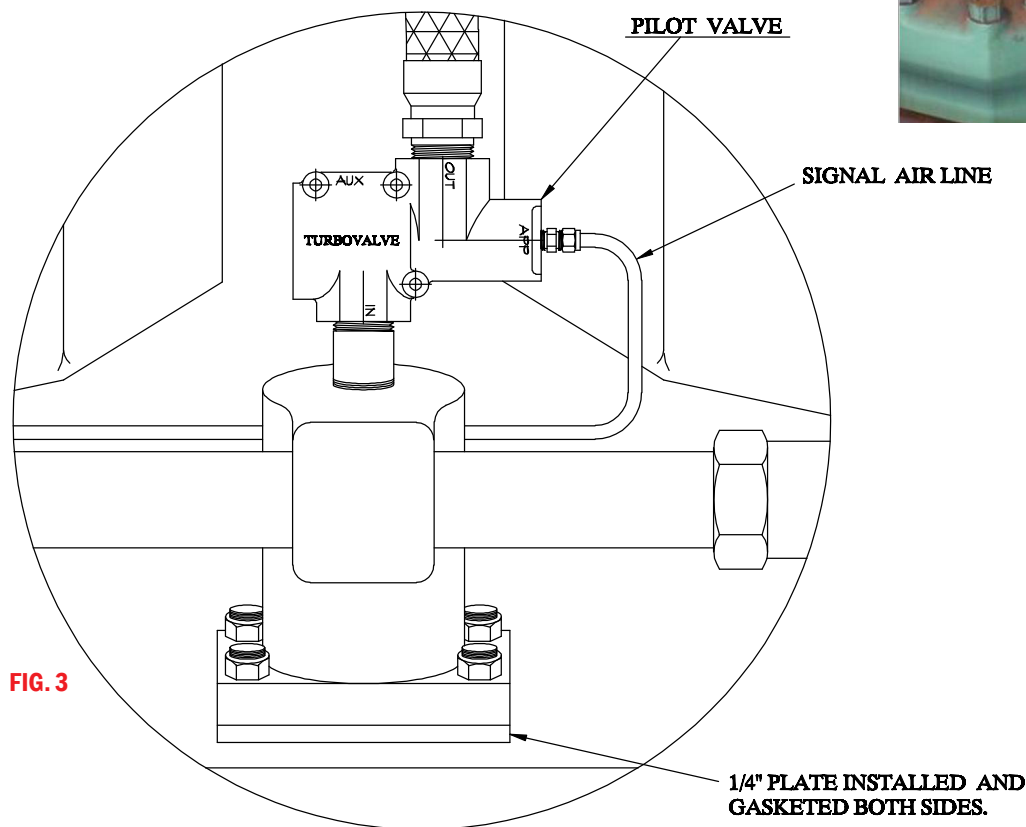

It is highly recommended that a thermocouple temperature protection system be installed to protect the hoses and valves in this system. Please refer to section 5.0 in the Operating Manual, Form SA-OM.

High pressure stainless steel hoses are necessary to allow the high pressure air (**150-250 PSI**) to travel from the relay valve to the top of each cylinder. **Exline/Altronic** offers these hoses in both **30"** and **48"** (**FIG. 4**) lengths, rated at **350 PSI/387°F**. These hoses have a **1.25"** NPT fitting on one end and a **1.5"** NPT fitting on the other, and, as a safety measure, there is a half-coupler welded to the male pipe end which accepts high-temperature shut-down devices (thermocouple or eutectic-pneumatic type).

As a safety precaution, most customers have opted to install a high pressure check valve (example: **RP&C Valve**) after the stainless steel hose on each cylinder. This protects the stainless hose from damage if the OEM check valve leaks or sticks open that would allow combustion pressure and heat to flow into the stainless hose.

HBA and **HLA** engines have similar bolt patterns that are very close when measured. Because this measurement is so close, **Exline/Altronic** offers a **3-ring** set (loaned on request) that can be used to verify which bolt pattern is needed for the **Logic/Distribution Mounting Adapter**.

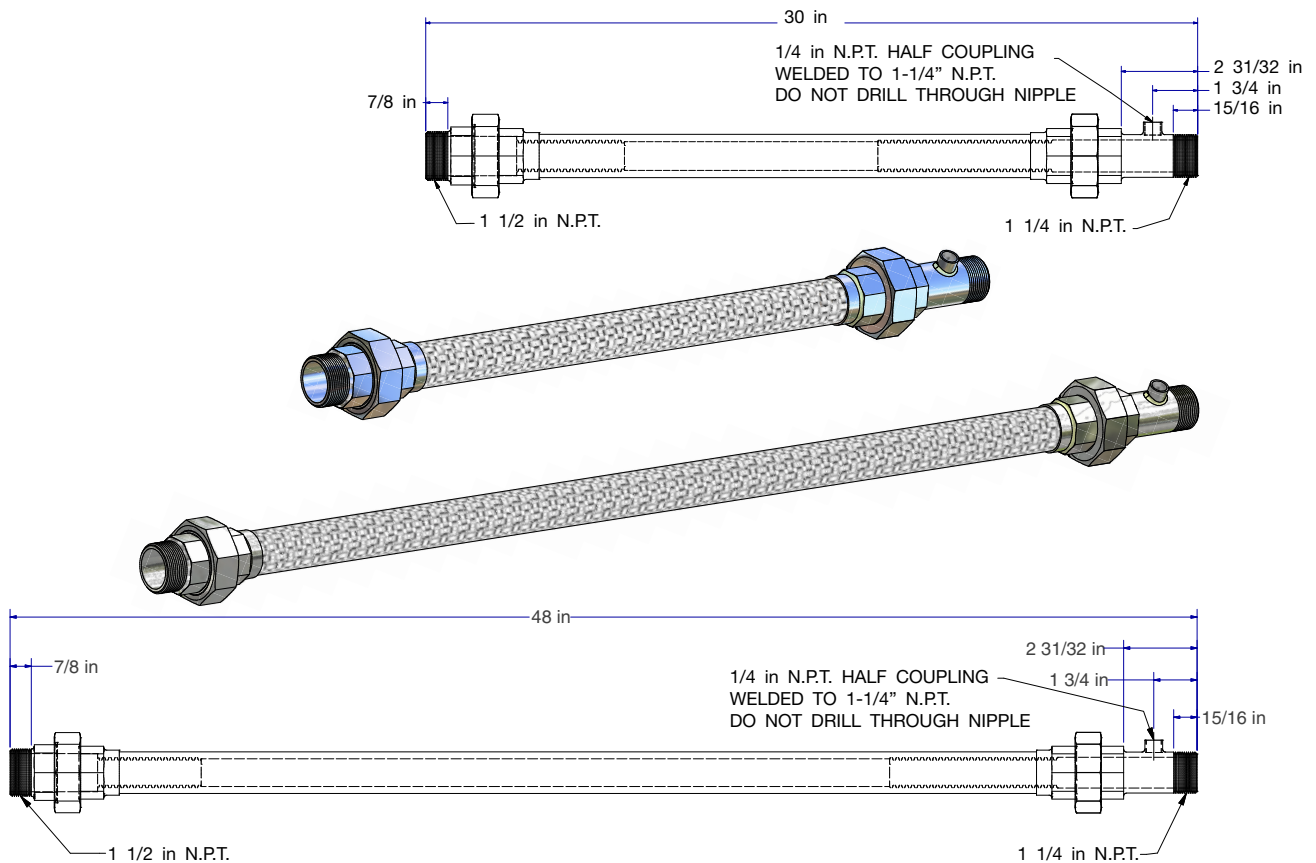

FIG. 4