

Installation and Operating Manual

NGI-1000 Digital Ignition System

Form NGI-1000 IOM 10-17



altronic

**NGI-1000
IGNITION SYSTEM**

- HV
- DIAGNOSTIC
- +24V

P/N **791973-16** S/N **110**



RATED: 20-32VDC, 7.5 AMPS MAX.
RATED AMBIENT: -40 TO +85 DEGREES C.
WARNING - EXPLOSION HAZARD - DO NOT CONNECT WHILE CIRCUIT IS LIVE UNLESS AREA IS KNOWN TO BE NON-HAZARDOUS

ALTRONIC, LLC GIRARD, OHIO USA U.S. PATENT NO. 7,401,603
HOERBIGER

1.0 DESCRIPTION

- 1.1 This manual provides installation and operating instructions for the Altronic NGI-1000 ignition system. It is recommended that the user read this manual in its entirety before commencing operations.
- 1.2 The Altronic NGI-1000 ignition system consists of these basic components:
 - NGI-1000 Unit, P/N 791973-x
 - Magnetic Pickup or Hall Effect Sensor (one per system)
 - Input Harness (one per system)
 - Output Harness (one per system)
 - Ignition coils (one per cylinder)
- 1.3 The system requires a battery or a suitable power supply with a nominal 24Vdc (see Fig. 2). The NGI-1000 unit steps up the DC supply voltage to charge an energy storage capacitor and contains a microprocessor and solid-state switching devices to release the stored energy to the ignition coils in programmed, timed sequence according to the application. Holes (one per cylinder) in a special timing disc signal the position of the engine crankshaft to the electronic circuitry in the NGI-1000 unit. One additional hole trails after the last cylinder hole; this is the index signal that another revolution has started. Ignition timing may be varied by means of a manual switch, an analog timing signal and/or engine RPM.
- 1.4 The NGI-1000 system can operate as a single-firing or double-firing (firing on exhaust stroke) system up to sixteen (16) cylinders. These instructions detail 8- and 16-cylinder, single-firing applications using NGI-1000 units 791973-x.
- 1.5 As shipped from the factory, the NGI-1000 is in the auto-detect mode and is set up for a trigger disc running at camshaft speed. The setup is programmable by the use of the PC compatible NGI-1000 terminal program (see section 10) available in the Terminal Programs section of the Downloads page of <http://www.Altronic-llc.com>. The programming of the unit is done via the RS-485 Modbus compatible communications port.

WARNING: Deviation from these instructions may lead to improper operation of the machine which could cause personal injury to operators or other nearby personnel.

2.0 NGI-1000 UNIT

- 2.1 Select a location for the NGI-1000 unit that will be at least 24 inches (600 mm) away from the ignition coils and spark plug leads. In addition, the mounting location must be relatively cool, preferably one benefitting from the engine fan stream (if any); the outside case temperature of the NGI-1000 unit should not exceed 185°F. (85°C.) in continuous operation.
- 2.2 Secure the NGI-1000 unit to a suitable mounting bracket with provided vibration isolators. Refer to Fig. 1 for NGI-1000 unit dimensions.

3.0 PICKUP SENSOR – CAMSHAFT DISC

- 3.1 A disc with the appropriate hole pattern must be prepared for mounting at CAM-SHAFT speed. The disc must be of magnetic material and 4.0" (100mm) diameter or larger. Fig. 3 details the hole spacing depending on the number of engine cylinders. Note the direction of rotation of the disc. The angular spacing is extremely important as this establishes the basic timing accuracy of the system.
- 3.2 Locate a suitable mounting position for the pickup sensor in order to sense the holes in the rotating disc. Secure the pickup to a rigid bracket or surface. See Fig. 3 for the dimensions of the 3/4"-16 pickup sensors.
- 3.3 Set the engine with no. 1 cylinder in the most advanced timing position. Noting the direction of rotation, set the drilled disc opposite the pickup in the position shown in Fig. 4.

NOTE: Some MAN engines have a 12mm thread port; use Altronic pickup 791035-2 or 791041-3.

3.4 Adjust the tightening nut holding the pickup sensor to maintain an air gap as specified below:

- For magnetic pickups 791015-1 and 791016-2, the gap shall be set to $.020" \pm .005"$ (0.50 mm \pm 0.12 mm).
- For magnetic pickups 791035-2 and 791041-3 (12 mm thread), the gap shall be set to $.014" \pm .004"$ (0.35 mm \pm 0.10 mm).

The center of the pickup face must line up with the center of each drilled hole as the disc rotates.

3.5 Plug the 2-pin pickup connector fully into the mating connector of the NGI-1000 wiring harness.

3.6 It is possible to use optional pickup sensors. A hall effect and powered magnetic pickup. Each require three wires and send a transitional zero or five volt signal. When using either of these options, the Powered Pickup check box must be turned on (blue). With the powered pickup option ONLY, the edge sensed is selectable. For Rising Edge, the box is unchecked and for Falling Edge, the box is checked (blue).

4.0 IGNITION COILS

4.1 Use only the Altronic coils indicated here:

- UNSHIELDED: 501061, 591010
- FLANGE: 591012, 591018

4.2 Mount the ignition coils as close to the spark plugs as possible keeping the high-tension lead length to a minimum but also keeping temperatures below 200°F. (95°C.) during operation.

5.0 PRIMARY WIRING

5.1 The NGI-1000 system requires a battery or other DC power source providing 24Vdc nominal. Refer to Fig. 2 for details of the connection to the DC power source.

5.2 Use the tables below to record the actual firing order and wiring.

791973-8	A	B	C	D	E	F	K	L
ENGINE CYL. NO.								

791973-12	A	B	C	D	E	F	K	L	M	N	P	R
ENGINE CYL. NO.												

791973-16	A	B	C	D	E	F	K	L	M	N	P	R	S	T	U	V
ENGINE CYL. NO.																

The common coil ground lead on all units is the J harness lead.

5.3 All connections at unshielded coils should be made using ring-type terminals specified for 16 AWG (1.5 sq. mm) wire and #10 (5mm) stud size. Terminals should either be soldered to the wire or attached with an appropriate staking tool. Protect primary wiring from physical damage, vibration and temperatures in excess of 200°F. (95°C.).

5.4 For details of the hookup for the analog timing signal, see Fig. 7.

5.5 Be sure the multi-pin harness connectors are fully plugged into the mating receptacles connected to the NGI-1000 unit.

NOTE: Keep the pickup sensor wires at least 2" (50mm) away from the coil primary wires and at least 8" (200mm) away from the spark plug leads.

NOTE: Upon changing from non-powered to powered and vice versa, the unit must be rebooted.

Check the powered pick up for normal high or normal low operation. Rising edge will be leading on normal low and lagging on normal high. This will affect ignition timing the length of the indicator in the disc if not selected properly.

WARNING: The hookup shown is for the most common engine firing order. Connect to the ignition coils according to the actual engine firing order.

NOTE: On certain 12- and 16-cylinder engines, a cylinder other than no. 1 (typically the second cylinder in the firing order) must be used when lining up the disc and pickup.

NOTE: Keep the primary wiring at least 2" (50mm) away from the spark plug leads.

6.0 SHUTDOWN WIRING

- 6.1 The NGI-1000 system is shut-off by interrupting the DC power to the unit; use a switch or relay with contacts rated 24Vdc, 12Amps minimum - refer to Fig. 2.
- 6.2 The NGI-1000 can also be shutdown by using the G-lead of the output harness. To shutdown the unit, connect the G-lead of the output harness to ground. The NGI-1000 will draw about 0.1 ampere from the power source when shutdown.

NOTE: Do NOT run the input power line through a series of normally closed switches.

7.0 SECONDARY WIRING

- 7.1 With unshielded coils, spark plug leads should be fabricated from 7 mm, silicone insulated, ignition cable with suitable terminals and silicone spark plug boot.
- 7.2 Keep spark plug leads as short as possible and at least 2 inches (50 mm) away from any grounded engine part. In deep spark plug wells, use rigid, insulated extenders projecting out of the well.
- 7.3 The use of a clear, silicone grease (such as Dow Corning DC-4, G.E. G-623 or GC Electronics Z5) is recommended for all high-tension connections and boots. This material helps seal out moisture and prevent corrosion from atmospheric sources.

NOTE: The NGI-1000 should not be used to power ignition-powered panel instruments.

NOTE: The use of resistance spark plug cable or individual 5,000 ohm resistors (mounted either at the spark plug or coil) is recommended.

8.0 OPERATION

8.1 IGNITION DELAY:

On cranking, there will be a delay of two disc revolutions—after the power is ON and the engine begins rotating—before the NGI-1000 unit commences outputs to the ignition coils. This delay is to allow identification of the pick-up index hole to insure proper synchronization with the engine. A greater delay of more revolutions to allow for engine purging can be added to the programming. See Section 10.12.

NOTE: On the first start-up after system installation, verify correct ignition timing by cranking the engine with the fuel supply shut off.

8.2 MANUAL TIMING SWITCH:

The NGI-1000 unit has a TIMING switch located under a white plastic cap at the end of the case. Using a timing light, set the timing to the desired position with the engine running at NORMAL OPERATING SPEED. Replace the white cap over the timing switch once the proper timing is set. Switch position 7 gives the most advanced timing. The timing retards approximately one (1) engine degree for each switch position as the switch is moved to position 6, 5, 4, 3, 2, 1, 0. Switch position 0 is full retard. Larger timing changes per switch position can be programmed. See Section 10.

NOTE: DO NOT switch from position 7 to 0, or 0 to 7 while the engine is running. The large timing change may cause the engine to shutdown or be damaged.

8.3 ANALOG TIMING ADJUSTMENT:

The NGI-1000 unit provides for analog timing adjustment in two ways:

- 0-1000 ohm potentiometer connected between terminals E and F of the input harness.
- 4-20mA signal applied to leads F and G of the input harness.

NOTE: The analog timing retard is added to the retard established by the manual timing switch (see Section 8.2 above and Fig. 7).

8.4 RPM BASED TIMING CURVE:

The NGI-1000 unit is shipped with an RPM-based timing curve (default programming) providing a 6-degree advance as the engine speed increases from 0 to 600 RPM (Fig. 7). This timing change is in addition to changes made with the manual switch (Section 8.2) or the analog timing input (Section 8.3).

NOTE: When checked at different speeds, timing will vary in accordance with the programmed RPM curve indicated.

9.0 CUSTOMIZING THE NGI-1000 UNIT

9.1 Through the use of the PC terminal display, customizing the NGI-1000 ignition module is possible. The NGI-1000 takes advantage of the patented Varispark technology as well as maintains the ability to have a traditional CD spark. Once in the terminal display the secondary energy can be modified to optimize engine performance. The process is intuitive and straight forward as the units are displayed as mA (current in the spark) and uS (length of the spark in microseconds).

9.2 SPARK CURRENT:

When setting the spark current this can either be a traditional CD spark, or a Varispark both operating at 185V DC. Using the dropdown window a list of currents is available. As displayed, each mA value describes the current in the spark. Any value with a “+” sign provides the mA value initially and rises at a linear rate over the length of time selected in the next step.

9.3 SPARK DURATION:

To set the spark duration a second drop down menu is available. Each spark length is depicted in uS and is matched with the spark current. The NGI-1000 will hold the selected spark current for the duration, or length, for up to a maximum of 250W.

9.4 ENGINE PERFORMANCE:

It is important to tailor the spark current and duration to the engine demands. By applying the best spark profile, it will help to ensure that the spark plug wear and engine performance meet expectations. Things to take into consideration are spark plug interval changes, spark plug kV at end of life, and the demand of the spark plug over the entire engine load. It is recommended to monitor for engine misfire at all load conditions and tune the spark as necessary, using the current and duration menus. Higher current short duration profiles will generate a lot of initial energy to ignite a poor gas mixture. While a longer duration spark will help to keep a mixture lit longer into the rotation cycle.

10.0 PC TERMINAL DISPLAY FUNCTIONS

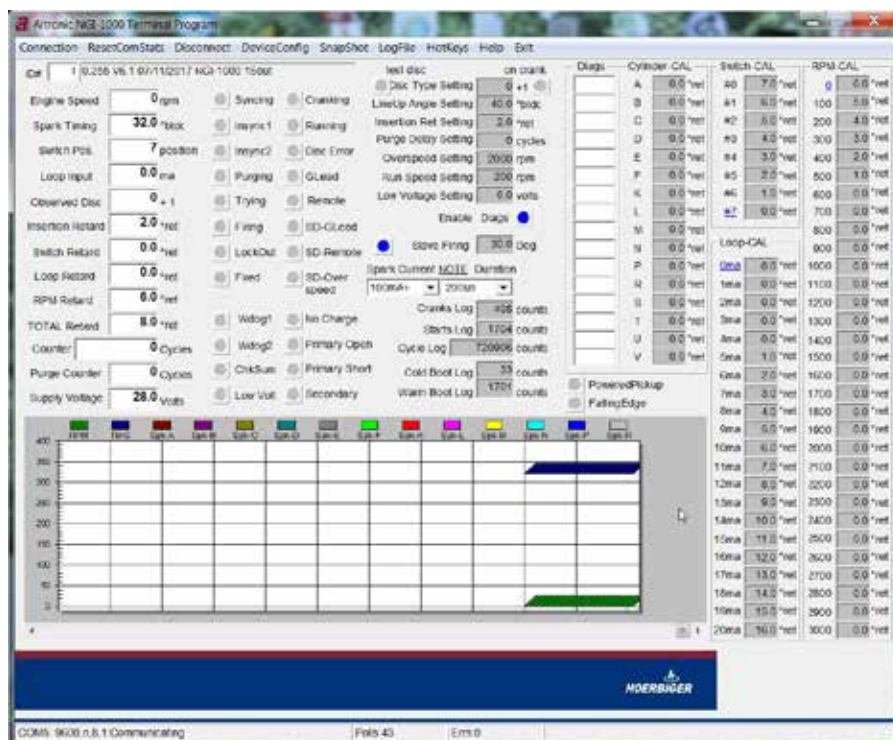

- 10.1 **ENGINE SPEED:**
Indicates current speed of the engine in RPM based on disc signal.
- 10.2 **SPARK TIMING:**
Indicates the global spark timing of the engine in degrees before TDC. This number is the LINE UP ANGLE setting less the TOTAL RETARD. Slight differences between this number and the timing reading obtained with a timing light may occur since the LINE UP ANGLE entered may differ slightly from the actual angular position of the engine when the input pulse event is received by the NGI-1000. In this event, the Spark Timing number should be made to agree with the timing light by changing the LINE UP ANGLE entry.
- 10.3 **SWITCH POSITION:**
Indicates the current position of the manual timing switch on the NGI-1000 case.
- 10.4 **LOOP INPUT:**
Indicates the value of the external input current loop.
- 10.5 **OBSERVED DISC:**
Indicates the number of input events (timing holes or protrusions) being recognized by the NGI-1000 unit on the timing disc input signal at this time.
- 10.6 **INSERTION RETARD:**
Indicates the amount of electronic insertion retard at this time.
- 10.7 **SWITCH RETARD:**
Indicates the amount of timing retard being added by the current timing switch position at this time.
- 10.8 **LOOP RETARD:**
Indicates the actual amount of timing retard added from the current loop versus retard lookup table curve at this time.
- 10.9 **RPM RETARD:**
Indicates the actual amount of timing retard being added by the RPM versus retard lookup table curve at this time.
- 10.10 **TOTAL RETARD:**
Indicates the total global timing retard at this time. This number is the sum of the Insertion Retard, Switch Retard, Loop Retard and RPM Retard.
- 10.11 **COUNTER:**
Indicates the number of disc rotations (engine cycles) registered since the engine was last started.
- 10.12 **PURGE COUNTER:**
During a startup, indicates the number of purge cycles remaining before the outputs are activated.
- 10.13 **SUPPLY VOLTAGE:**
Indicates the measured DC voltage supply level to the NGI-1000.
- 10.14 **SPARK REF. (A, B, C, ETC.):**
Indicates the current spark reference number for each cylinder.
- 10.15 **SYNCING:**
When red, indicates that engine rotation has been sensed and the synchronization process is taking place.
- 10.16 **INSYNC1:**
When red, indicates that the index input has been recognized once.
- 10.17 **INSYNC2:**
When red, indicates that the index has been recognized a second time and the ignition is ready to proceed.
- 10.18 **PURGING:**
When red, indicates that synchronization has been completed and the purge cycle countdown is taking place.

- 10.19 **TRYING:**
When red, indicates that the NGI-1000 is trying to fire outputs, but a proper primary discharge event has not yet occurred.
- 10.20 **FIRING:**
When red, indicates that NGI-1000 is successfully firing primary outputs.
- 10.21 **LOCKOUT:**
When red, indicates that firings are locked out until engine rotation has ceased for a minimum of 5 seconds.
- 10.22 **CRANKING:**
When red, indicates engine rotation below the Run Speed setting.
- 10.23 **RUNNING:**
When red, indicates engine rotation above the Run Speed setting.
- 10.24 **DISC ERROR:**
When red, indicates that the Test Disc status flag is activated and the timing disc pattern being sensed did not match the DISC TYPE selected.
- 10.25 **G-LEAD:**
When red, indicates that the G-lead is grounded.
- 10.26 **REMOTE:**
When red, indicates a remote serial shutdown command is active.
- 10.27 **SD-LEAD:**
When red, indicates that a shutdown has occurred which was the result of a grounded G-lead condition.
- 10.28 **SD-REMOTE:**
When red, indicates that a shutdown has occurred as a result of a remote serial shutdown command.
- 10.29 **SD-OVERSPEED:**
When red, indicates that a shutdown has occurred as a result of the engine reaching the Overspeed setting.
- 10.30 **WDOG1:**
When red, indicates that the microprocessor has re-booted since the ignition has been powered-up.
- 10.31 **WDOG2:**
When red, indicates that the microprocessor is currently re-booting. Disregard the first blink when first connecting.
- 10.32 **CHKSUM:**
When red, indicates a software checksum failure of the unit's firmware.
- 10.33 **LOW VOLT:**
When red, indicates that the input DC voltage is at or below the Low Voltage setting input.
- 10.34 **NO CHARGE:**
When red, indicates that the primary storage capacitor has failed to charge properly within the last ~2 seconds.
- 10.35 **PRIMARY OPEN:**
When red, indicates that an open primary condition has been detected within the last ~2 seconds.
- 10.36 **PRIMARY SHORT:**
When red, indicates that a shorted primary condition has been detected within the last ~2 seconds.
- 10.37 **SECONDARY OPEN:**
When red, indicates that an open secondary condition has been detected within the last ~2 seconds.

- 10.38 **CRANKS LOG:**
Indicates the total number of crank attempts seen by the NGI-1000.
- 10.39 **STARTS LOG:**
Indicates the total number of successful starts seen by the NGI-1000 as defined by the Run Speed setting input.
- 10.40 **CYCLE LOG:**
Total number of engine cycles seen by the NGI-1000.
- 10.41 **COLD BOOT LOG:**
Indicates the number of times the input DC voltage has been cycled to zero.
- 10.42 **WARM BOOT LOG:**
Indicates the number of times the microprocessor has restarted without a complete loss of power.
- 10.43 **GRAPHIC DISPLAY:**
The NGI-1000 Terminal Software provides a real time graphic display of the secondary diagnostic numbers, global engine timing (y-axis/10) and engine speed (y-axis x 10).
- 10.44 **POWERED PICKUP:**
Selectable for Hall effect or Powered Magnetic Pickup option. Turns blue when activated.
- 10.45 **FALLING EDGE:**
Selectable when using Powered Pickup. Turns blue when using Falling Edge.

NOTE: Check the polarity of powered pickup for normal high or normal low operation. Ignition timing can be affected.

11.0 NGI-1000 UNIT LED DIAGNOSTIC BLINK CODES

- 11.1 **NGI-1000 IGNITION BLINK CODES:**
Whenever the LED Diags status flag is enabled (blue) by using the NGI-1000 Terminal Software, the blinking pattern of the LED on the side of the NGI-1000 case can be used to interpret the general status of the NGI-1000 diagnostics without the use of the Terminal Software. Within each group of conditions described below, the possible diagnostic states are listed according to their number of blinks. The LED is ON for about 2 seconds between each blink sequence and the blinks occur evenly spaced at a faster rate.
- 11.2 **LED SIGNALS WITH THE ENGINE STOPPED:**
 - ON – STEADY = READY** (new power up or last start attempt aborted)
 - ON – 1 BLINK – ON = FIRED LAST TIME ROTATING** (stopped due to stall)
 - ON – 2 BLINK – ON = SHUTDOWN** (by grounding G-LEAD when running)
 - ON – 3 BLINK – ON = SHUTDOWN** (by remote serial request when running)
 - ON – 4 BLINK – ON = SHUTDOWN** (by overspeed when running)
 - ON – 5 BLINK – ON = WRONG DISK PATTERN**
 - ON – 6 BLINK – ON = LOW SUPPLY VOLTAGE** (below threshold when running)
- 11.3 **LED SIGNALS WITH ENGINE CRANKING** (rotating, and still below running RPM):
 - ON/OFF/ON/OFF = PURGING** (off first input pulse, toggles each revolution of purge)
 - ON – STEADY = FIRING NORMALLY** (RPM below running set point value)
 - OFF = WRONG DISC PATTERN DETECTED**
- 11.4 **LED SIGNALS WITH ENGINE RUNNING** (when firing, and above run speed):
 - ON – STEADY = FIRING NORMALLY** (no diagnostics to report)
 - ON – 1 BLINK – ON = OPEN SECONDARY ALARM**
 - ON – 2 BLINK – ON = PRIMARY SHORT ALARM**
 - ON – 3 BLINK – ON = PRIMARY OPEN ALARM**

ON – 4 BLINK – ON = NO CHARGE ALARM
ON – 6 BLINK – ON = LOW SUPPLY VOLTAGE

12.0 RS-485 COMMUNICATIONS, MODBUS RTU

12.1 The NGI-1000 is compliant to the Modbus RTU standard. Maximum number of registers that can be read at one time is limited to 32. Maximum number of booleans that can be read at one time is limited to 256. All communications are 8 data bits, no parity, 1 stop bit. The baud rate is 9600. The MODBUS address list follows:

12.2 2 read/write coil bits pickup settings

ADDRESS	FUNCTION
00007	Trigger Edge RISING=0 FALLING=1
00008	Pickup Type PASSIVE=0 POWERED=1

12.3 24 read-only status bits, readable in multiples of 8 bits starting at 8-bit boundaries

ADDRESS	FUNCTION
10001	Syncing
10002	InSync1
10003	InSync2
10004	Purging
10005	Trying
10006	Firing
10007	LockOut
10008	FIRE
10009	Cranking
10010	Running
10011	Wrong Disk
10012	GLead Shutdown Grounded
10013	Remote Shutdown Present
10014	GLead Shutdown Logged
10015	Remote Shutdown Logged
10016	Overspeed Shutdown Logged
10017	WDOG1 Reset Latched
10018	WDOG2 Reset Event
10019	Checksum Error
10020	LOW Supply Voltage
10021	No Charge
10022	Open Primary
10023	Shorted Primary
10024	Open Secondary

WARNING: Writable Modbus registers such as '0XXXX' and '4XXXX' directly reference the CD200D non-volatile memory. Non-volatile memory has a useful life of ~100,000 Write/Erase cycles. Any device writing to these registers must take care to not exceed the maximum number of Write/Erase cycles.

12.4 Read-only status registers

ADDRESS	FUNCTION		
30001	Input Bit Mirror	10016–10001	
30002	Input Bit Mirror	10032–10017	
30003	Input Bit Mirror	10048–10033	
30004	Input Bit Mirror	10064–10049	
30005	RPM		
30006	Timing	xxx.xDEG	signed
30007	Switch	Position	1–8
30008	Current Loop Input	xx.xmA	
30009	Disk	Observed X+1	
30010	Insertion	Retard	xxx.xDeg
30011	Switch	Retard	xxx.xDeg
30012	Loop	Retard	xxx.xDeg
30013	RPM	Retard	xxx.xDeg
30014	Total	Retard	xxx.xDeg
30015	Cycle Counter HI		
30016	Cycle Counter LO		xx.xVolts
30017	Supply Voltage		
30018	Spark Ref. Num. Output A		
30019	Spark Ref. Num. Output B		
30020	Spark Ref. Num. Output C		
30021	Spark Ref. Num. Output D		
30022	Spark Ref. Num. Output E		
30023	Spark Ref. Num. Output F		
30024	Spark Ref. Num. Output K		
30025	Spark Ref. Num. Output L		
30026	Spark Ref. Num. Output M		
30027	Spark Ref. Num. Output N		
30028	Spark Ref. Num. Output P		
30029	Spark Ref. Num. Output R		
30030	Spark Ref. Num. Output S		
30031	Spark Ref. Num. Output T		
30032	Spark Ref. Num. Output U		
30033	Spark Ref. Num. Output V		
30034	Purge Delay Index Down Counter		
30035	Distributor MUX code 0–15		
30036	KEYCOMMAND		
30037	Period Predivider		
30038	Period MS16BITS		
30039	Period LS16BITS		
30040	FireStat:DelayStat		

12.5 **8 read/write configuration bits, supports write single only, readable in multiples of 8 bits starting at 8 bit boundaries**

ADDRESS	FUNCTION
1	DISK ON CAM=0 CRANK=1
2	TEST FOR PROPER DISK YES=1
3	ENABLE SECONDARY DIAGS YES=1
4	RESERVED
5	RESERVED
6	SLAVE
7	reserved
8	OFF = MAGNETIC Pickup ON = HALL-EFFECT Pickup

12.6 **4 read/write registers mirror coil bits**

ADDRESS	FUNCTION
40001	REG40001=CoilBits 00016-00001
40002	REG40002=CoilBits 00032-00017
40003	REG40003=CoilBits 00048-00033
40004	REG40004=CoilBits 00064-00049

12.7 **8 read/write registers regarding application**

ADDRESS	FUNCTION
40005	Disk+1 2,3,4,5,6,7,8,9,10,12
40006	Disk Lineup to TDC xx.x DEG
40007	Insertion Ret MIN=2.0 DEG xx.x
40008	Purge Delay Cycles 0-255
40009	RPM Over Speed Setpoint
40010	RPM Crank to Run Threshold
40011	Low Supply Voltage Limit xx.xV
40012	SLAVE ANGLE xx.x DEG

12.8 **2 read/write registers for spark control**

ADDRESS	FUNCTION
40013	Spark Duration Control 200uS=0 250uS=1 ... 1000uS=16
40014	Spark Current Control C.D.=0 50mA=1 50mA+=2 ... 200mA=7

12.9 **16 read/write registers for cylinder ret. table**

ADDRESS	FUNCTION
40017	OUTPUT A EXTRA RETARD DEG
40018	OUTPUT B EXTRA RETARD DEG
40019	OUTPUT C EXTRA RETARD DEG
40020	OUTPUT D EXTRA RETARD DEG
40021	OUTPUT E EXTRA RETARD DEG
40022	OUTPUT F EXTRA RETARD DEG
40023	OUTPUT K EXTRA RETARD DEG
40024	OUTPUT L EXTRA RETARD DEG
40025	OUTPUT M EXTRA RETARD DEG

12.9 **16 read/write registers for cylinder ret. table (continued)**

ADDRESS	FUNCTION
40026	OUTPUT N EXTRA RETARD DEG
40027	OUTPUT P EXTRA RETARD DEG
40028	OUTPUT R EXTRA RETARD DEG
40029	OUTPUT S EXTRA RETARD DEG
40030	OUTPUT T EXTRA RETARD DEG
40031	OUTPUT U EXTRA RETARD DEG
40032	OUTPUT V EXTRA RETARD DEG

12.10 **8 read/write registers for timing switch ret. table**

ADDRESS	FUNCTION
40033	TIMING SWITCH POS 0 DEG
40034	TIMING SWITCH POS 1 DEG
40035	TIMING SWITCH POS 2 DEG
40036	TIMING SWITCH POS 3 DEG
40037	TIMING SWITCH POS 4 DEG
40038	TIMING SWITCH POS 5 DEG
40039	TIMING SWITCH POS 6 DEG
40040	TIMING SWITCH POS 7 DEG

12.11 **21 read/write registers for loop ret. table**

ADDRESS	FUNCTION
40049	LOOP RET MAP 0mA 0.00V DEG
40050	LOOP RET MAP 1mA 0.25V DEG
40051	LOOP RET MAP 2mA 0.50V DEG
40052	LOOP RET MAP 3mA 0.75V DEG
40053	LOOP RET MAP 4mA 1.00V DEG
40054	LOOP RET MAP 5mA 1.25V DEG
40055	LOOP RET MAP 6mA 1.50V DEG
40056	LOOP RET MAP 7mA 1.75V DEG
40057	LOOP RET MAP 8mA 2.00V DEG
40058	LOOP RET MAP 9mA 2.25V DEG
40059	LOOP RET MAP 10mA 2.50V DEG
40060	LOOP RET MAP 11mA 2.75V DEG
40061	LOOP RET MAP 12mA 3.00V DEG
40062	LOOP RET MAP 13mA 3.25V DEG
40063	LOOP RET MAP 14mA 3.50V DEG
40064	LOOP RET MAP 15mA 3.75V DEG
40065	LOOP RET MAP 16mA 4.00V DEG
40066	LOOP RET MAP 17mA 4.25V DEG
40067	LOOP RET MAP 18mA 4.50V DEG
40068	LOOP RET MAP 19mA 4.75V DEG
40069	LOOP RET MAP 20mA 5.00V DEG

12.12 31 read/write registers for rpm ret. table

ADDRESS	FUNCTION
40070	RPM RET MAP 0000 RPM DEG
40071	RPM RET MAP 0100 RPM DEG
40072	RPM RET MAP 0200 RPM DEG
40073	RPM RET MAP 0300 RPM DEG
40074	RPM RET MAP 0400 RPM DEG
40075	RPM RET MAP 0500 RPM DEG
40076	RPM RET MAP 0600 RPM DEG
40077	RPM RET MAP 0700 RPM DEG
40078	RPM RET MAP 0800 RPM DEG
40079	RPM RET MAP 0900 RPM DEG
40080	RPM RET MAP 1000 RPM DEG
40081	RPM RET MAP 1100 RPM DEG
40082	RPM RET MAP 1200 RPM DEG
40083	RPM RET MAP 1300 RPM DEG
40084	RPM RET MAP 1400 RPM DEG
40085	RPM RET MAP 1500 RPM DEG
40086	RPM RET MAP 1600 RPM DEG
40087	RPM RET MAP 1700 RPM DEG
40088	RPM RET MAP 1800 RPM DEG
40089	RPM RET MAP 1900 RPM DEG
40090	RPM RET MAP 2000 RPM DEG
40091	RPM RET MAP 2100 RPM DEG
40092	RPM RET MAP 2200 RPM DEG
40093	RPM RET MAP 2300 RPM DEG
40094	RPM RET MAP 2400 RPM DEG
40095	RPM RET MAP 2500 RPM DEG
40096	RPM RET MAP 2600 RPM DEG
40097	RPM RET MAP 2700 RPM DEG
40098	RPM RET MAP 2800 RPM DEG
40099	RPM RET MAP 2900 RPM DEG
40100	RPM RET MAP 3000 RPM DEG

12.13 7 read/write misc. registers

ADDRESS	FUNCTION
40122	Crank Counter
40123	Start Counter
40124	Cycle Counter HIGH
40125	Cycle Counter LOW
40126	REG40005 MSB=BAUD LSB=NODEID fixed 9600n81:node1
40127	Cold Boot (powerup) Count
40128	Warm Boot (reset) Count

12.14 NGI-1000 Spark Control Table

NGI-1000 MODBUS / SPARK CONTROL DETAILS									
REG40014	Modbus	0	1	2	3	4	5	6	7
	Spark	CD	50mA	50mA+	100mA	100mA+	150mA	150mA+	200mA
REG40013									
Modbus	Time (uS)	N/A							
1	150		X	X	X	X	X	X	X
2	200		X	X	X	X	X	X	X
3	250		X	X	X	X	X	X	X
4	300		X	X	X	X	X	X	X
5	350		X	X	X	X	X	X	X
6	400		X	X	X	X	X	X	X
7	450		X	X	X	X	X	X	
8	500		X	X	X	X	X	X	
9	550		X	X	X	X	X		
10	600		X	X	X	X	X		
11	650		X	X	X	X	X		
12	700		X	X	X	X	X		
13	750		X	X	X	X			
14	800		X	X	X	X			
15	850		X	X	X				
16	900		X	X					
17	950		X	X					
18	1000		X	X					
19	1050		X	X					
20	1100	X	X						

Selections inside this region are beyond the safe operating range of the device. The device automatically limits itself for safe operation. Spark current selection with override duration.

REG00007 = PICKUP EDGE (0=RISING / 1=FALLING)
 REG00008 = PICKUP TYPE (0 = MPU / 1 = ACTIVE)
 (NOTE: Power must be cycled when making pickup configuration change)
 All other MODBUS is backward compatible to CD200/CD200D/CD200EVS

FIG. 1 NGI-1000 DIMENSIONS AND SPECIFICATIONS, 791973-X

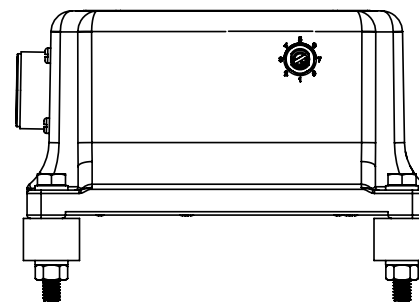
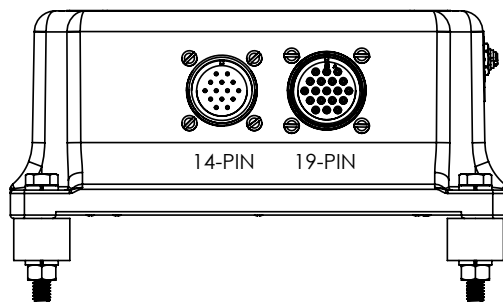
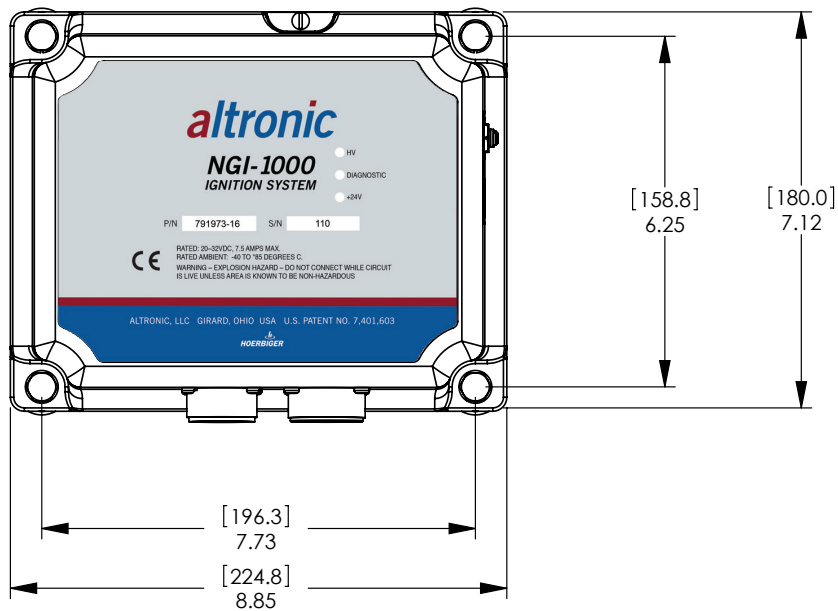

14-PIN CONNECTOR	
CONN. PIN	PCB HOLE
A	MPA
B	MPB
C	485 +
D	FLT
E	+5V
F	4-20 IN
G	4-20 -
H	485 -
I	N/C
J	N/C
K	+24 POWER SUPPLY
L	INPUT SIGNAL FROM POWERED PICKUP
M	+5V SUPPLY TO POWERED PICKUP
N	GROUND SIGNAL TO/FROM POWERED PICKUP

OPERATING TEMPERATURE: -40°C TO +85°C
 STORAGE TEMPERATURE: -40°C TO +105°C
 INPUT VOLTAGE: 24 VDC NOM.
 OUTPUT VOLTAGE: 185 VDC NOM.

FIG. 2 NGI-1000 OPERATING VOLTAGE REQUIREMENT

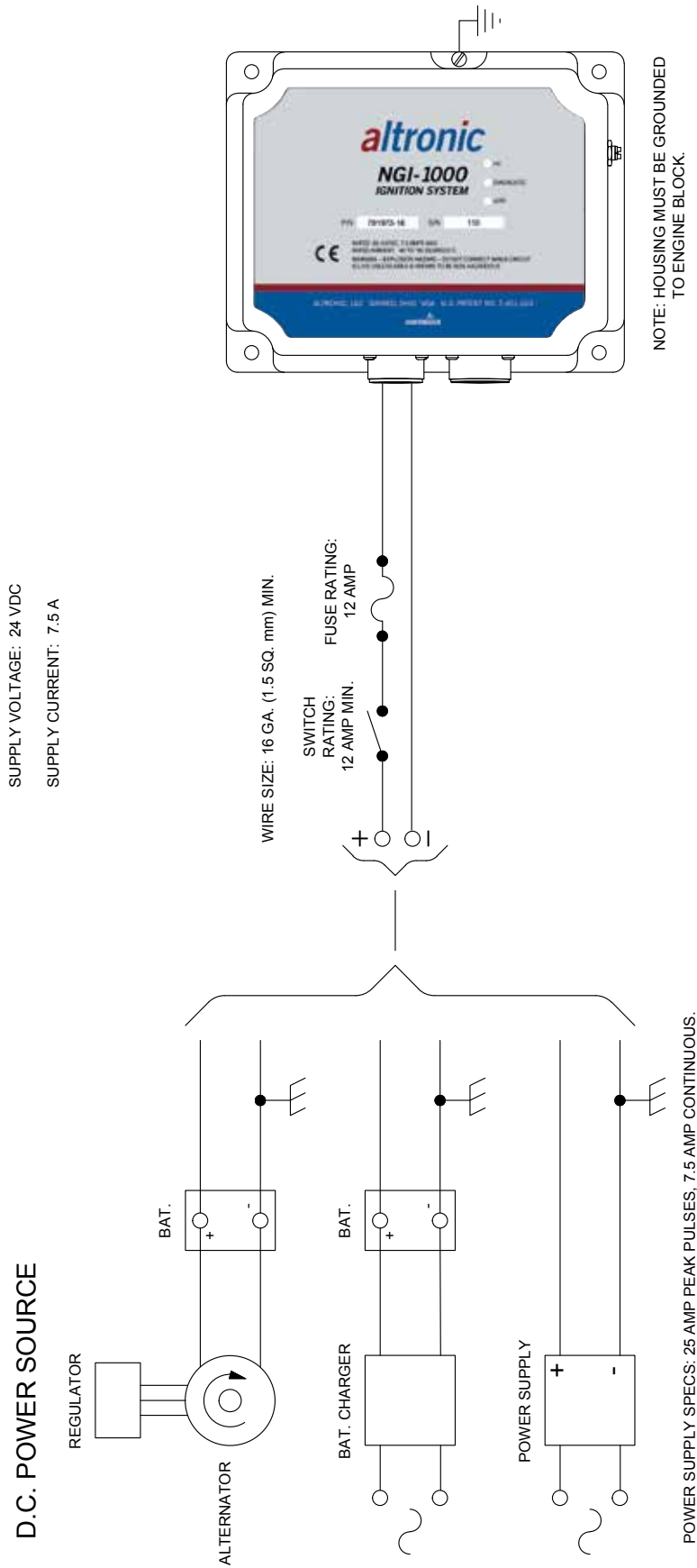

NOTE:

1. INFORMATION IS PER ONE (1) NGI-1000 SYSTEM FOR MULTIPLE SYSTEMS, MULTIPLY REQUIREMENTS BY NUMBER OF SYSTEMS.
2. POWER SUPPLY NEGATIVE MUST BE GROUNDED TO ENGINE BLOCK.

FIG. 3 NGI-1000 MAGNETIC PICKUP AND DISC HOLE DETAIL

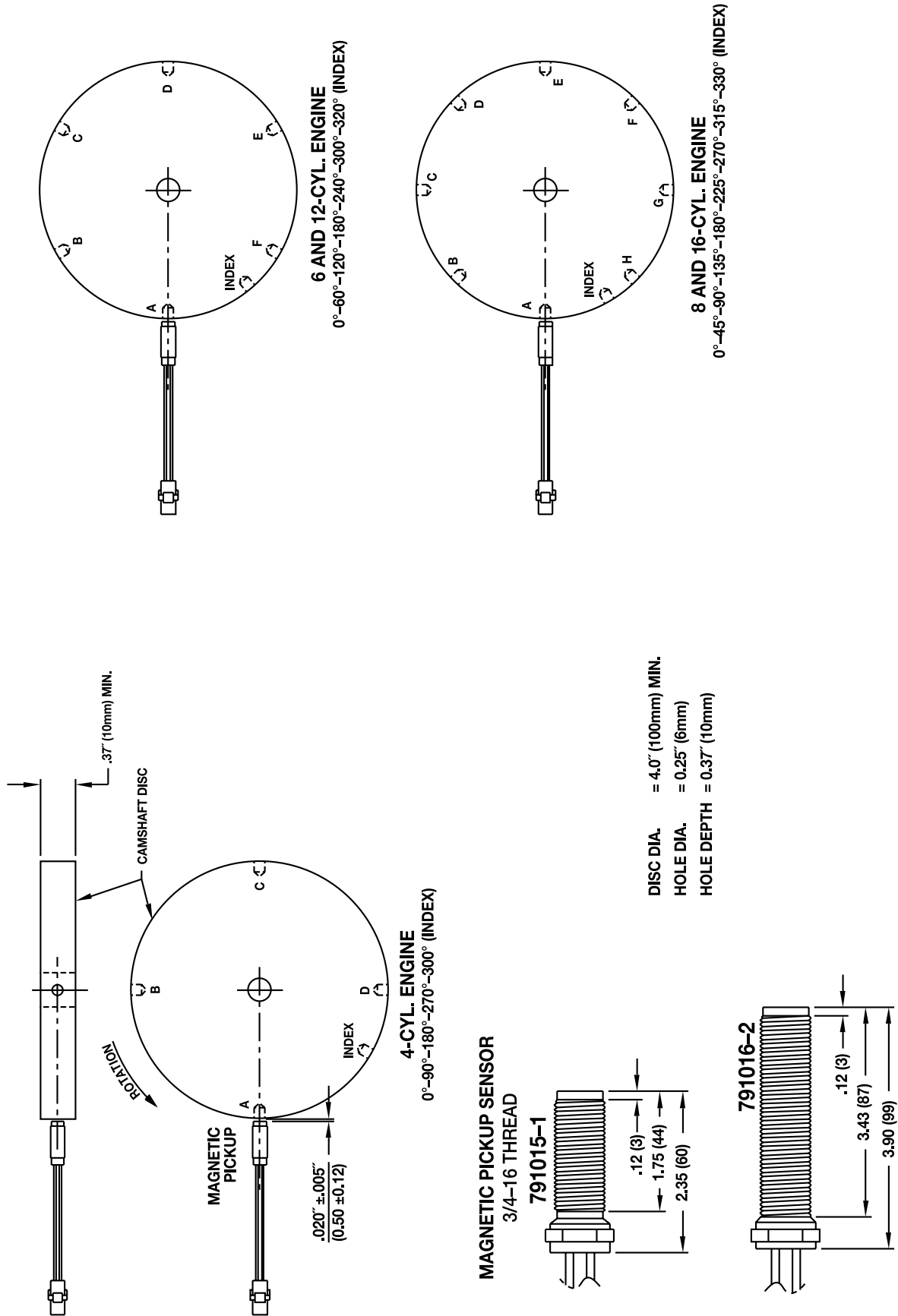
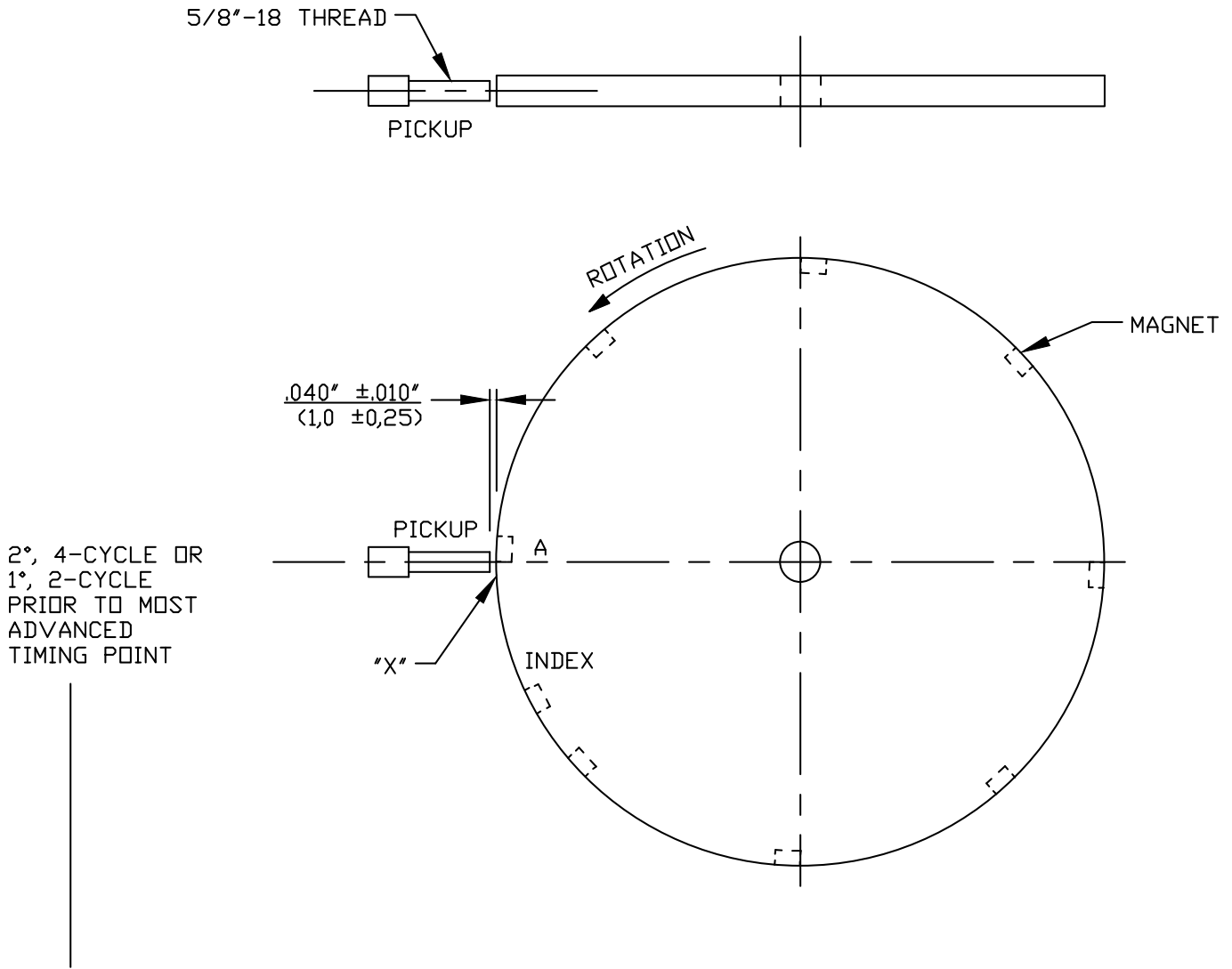

FIG. 4 NGI-1000 PICKUP AND DISC INSTALLATION



EXAMPLE: (4-CYCLE ENGINE)

MOST ADVANCED TIMING SETTING = 24° BTDC
 ENGINE SETTING FOR ABOVE LINE-UP = 26° BTDC
 ADJUSTABLE TIMING RANGE = 9°-24° BTDC

NOTE: (8 + 1) MAGNET DISC SHOWN.

FIG. 5 WIRING DIAGRAM TEMPLATE FOR SINGLE-FIRING SYSTEM WITH MAGNETIC PICKUP

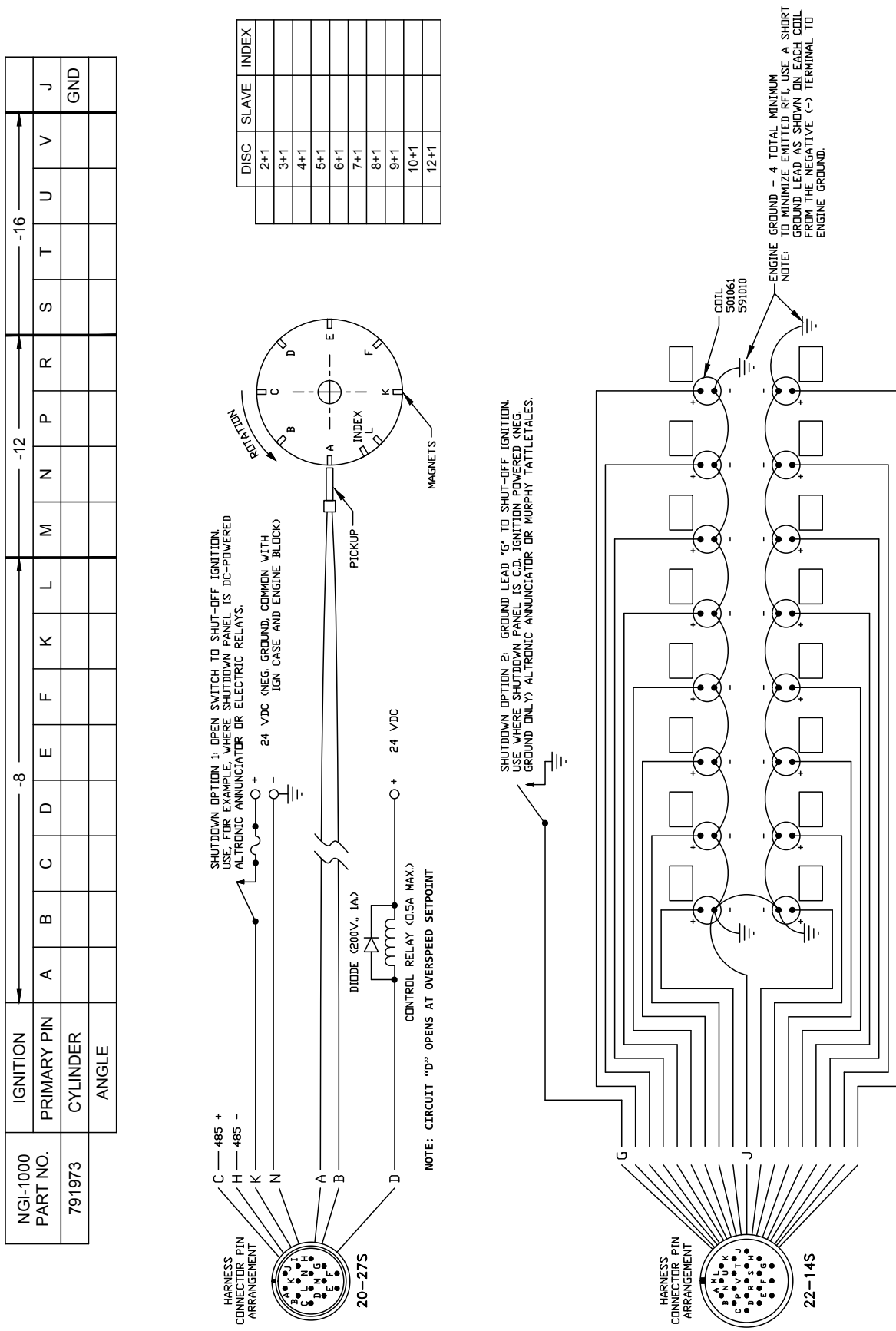

DISC	SLAVE	INDEX
2+1		
3+1		
4+1		
5+1		
6+1		
7+1		
8+1		
9+1		
10+1		
12+1		

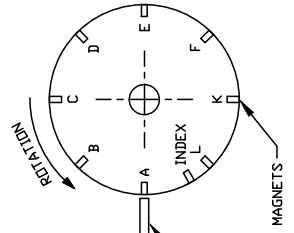

FIG. 6 WIRING DIAGRAM TEMPLATE FOR SINGLE-FIRING SYSTEM WITH POWERED PICKUP

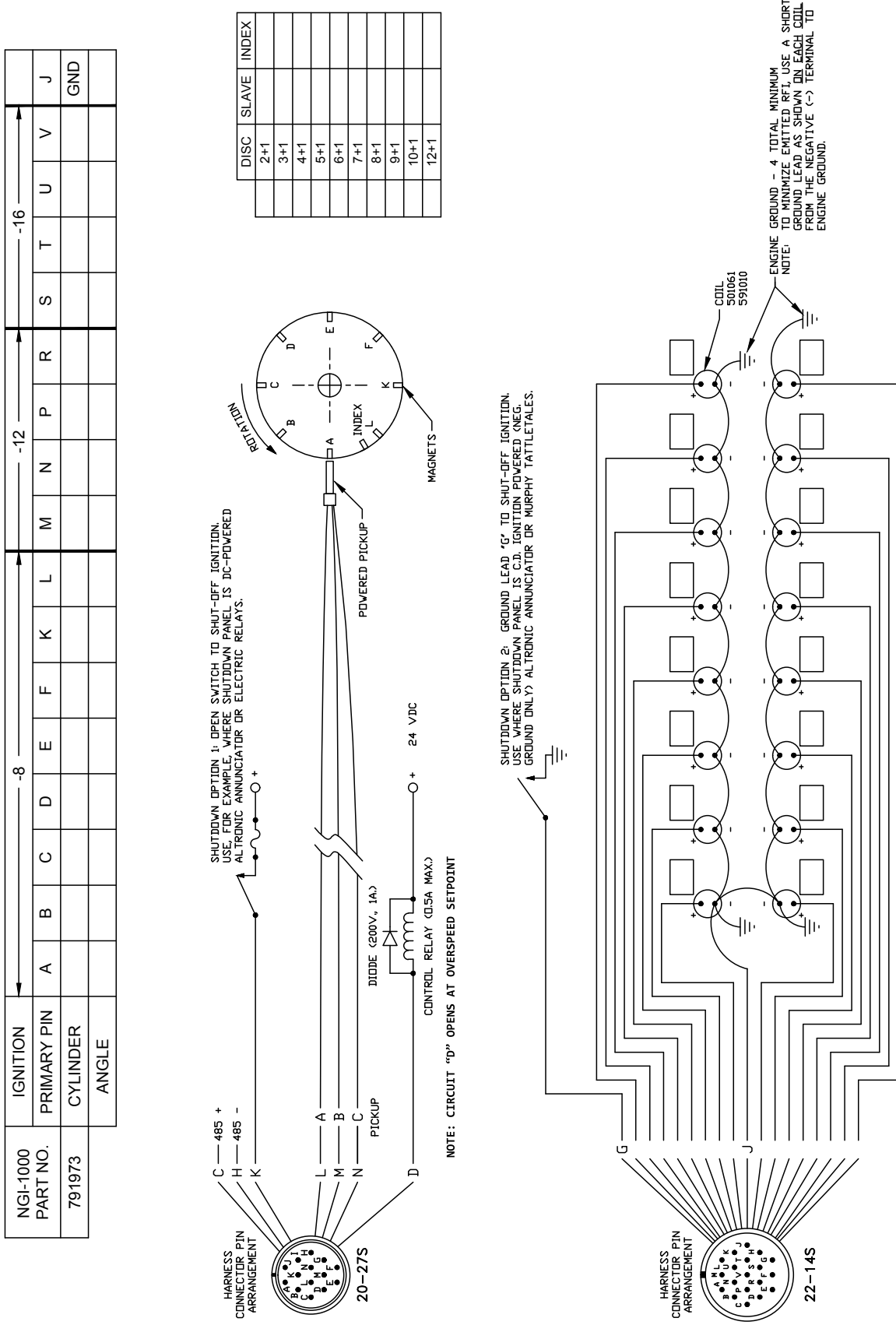
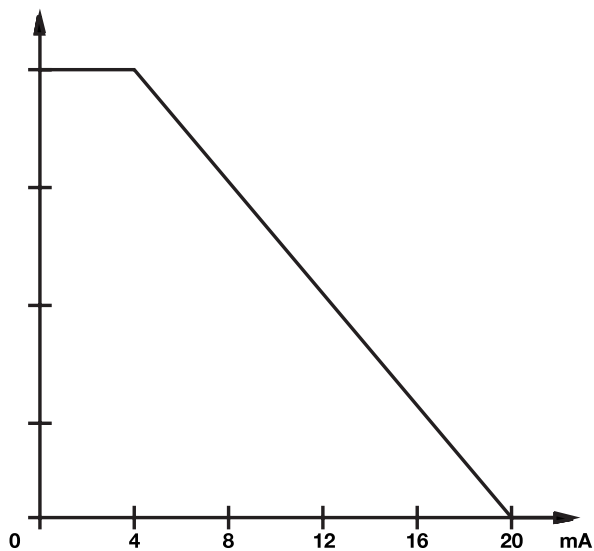
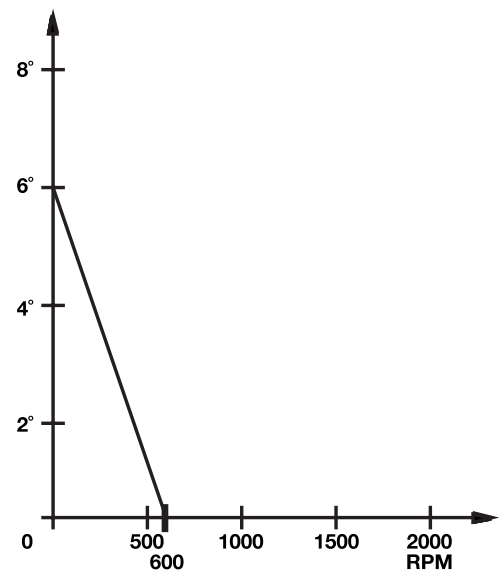

FIG. 7 NGI-1000 HOOK-UP FOR ANALOG TIMING SIGNAL

**EXAMPLE ANALOG TIMING CURVE – ENGINE DEGREES
DEGS. RETARD**



**EXAMPLE SPEED TIMING CURVE – ENGINE DEGREES
DEGS. RETARD**



**14-PIN INPUT/CONTROL CONNECTOR WIRING
OPTION 1 — POTENTIOMETER CONTROL**

PIN A	PIN B	PIN C	PIN D	PIN E	PIN F	PIN G	PIN H	PIN K	PIN L	PIN M	PIN N
+ MPU INPUT	- MPU INPUT	485 +	FAULT OUT	+ 5VDC 100mA MAX	ANALOG +	ANALOG -	485 -	24VDC	HEA	HEB	Power Supply/Powered Pickup Ground

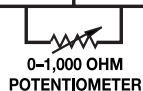

OPTION 2 — 4-20mA CONTROL

PIN A	PIN B	PIN C	PIN D	PIN E	PIN F	PIN G	PIN H	PIN K	PIN L	PIN M	PIN N
+ MPU INPUT	- MPU INPUT	485 +	FAULT OUT	+ 5VDC 100mA MAX	ANALOG +	ANALOG -	485 -	24VDC	HEA	HEB	Power Supply/Powered Pickup Ground

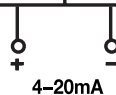

NOTE: INPUT CONNECTOR CIRCUIT AT PIN "D" OPENS WHEN ENGINE RPM EXCEEDS OVERSPEED SETTING. THE CIRCUIT REMAINS OPEN UNTIL ROTATION STOPS FOR APPROXIMATELY 4 SECONDS.

FIG. 8 PC TO NGI-1000

