

WARNING: DEVIATION FROM THESE INSTALLATION INSTRUCTIONS MAY LEAD TO IMPROPER ENGINE OPERATION WHICH COULD CAUSE PERSONAL INJURY TO OPERATORS OR OTHER NEARBY PERSONNEL.

1.0 OVERVIEW

- 1.1 The Altronic GOV Gas Engine Governor has been designed for application on large, natural gas fueled engines and integral compressors. The Governor is field-programmable and provides fuel control and engine speed control as well as diagnostic features. This manual provides instruction and maintenance information for the GOV10 and GOV50 models. It is recommended that the user read this manual in its entirety before commencing operations.

Do NOT attempt to operate, maintain, or repair the fuel control valve until the contents of this document have been read and are thoroughly understood.

- 1.2 The Altronic Gas Engine Governors must be used with clean, dry natural gas. Natural gas and air, when combined, become very combustible. When contained within an enclosure, such as a fuel-injected reciprocating engine or its exhaust system, this mixture combusts in a violent manner when ignited. It is necessary to always use extreme caution when working with any fuel system. The control systems used with natural gas fired, reciprocating engines should always be designed to be "fail-safe". Towards this goal, the GOV10/50 Gas Engine Governor plays an important part in the safety of the whole system.

WARNING: The GOV10/50 Gas Engine Governor is NOT a shutoff valve. Shutoff valves must be used in addition to the Gas Engine Governor. The fuel system should be designed in such a way that:

- 1. No single failure of a component can cause the fuel system to admit fuel to the engine when the engine has been shutdown.**
- 2. No single failure can result in grossly over-fueling the engine when attempting to start.**

FAILURE TO FOLLOW THE ABOVE RULES MAY LEAD TO POSSIBLY SERIOUS DAMAGE TO EQUIPMENT OR TO PERSONNEL.

- 1.3 The GOV10/50 Gas Engine Governor is designed for use as the speed control on fuel-injected reciprocating natural gas engines. The valve controls fuel flow by varying an orifice and uses fuel gas pressure for actuation muscle. The valve consists of a tubular main body, a poppet assembly, and an electronics component housing. These three main sub-assemblies form a single integrated unit. The GOV requires no separate actuators or mechanical linkage.

1.4 The main body contains an orifice plate (used for the optional flow measurement feature) and the poppet assembly. Mounting flanges are also bolted to the main body. The poppet assembly consists of the following:

- Poppet
- Poppet Seat
- Oil-filled bellows section for dampening
- Return Spring

The electronics housing contains:

- Control gas pressure regulator
- Muscle gas controlling components
- Three (3) pressure transducers
- ΔP transducer
- Fuel temperature RTD

1.5 The Governor Display Module accomplishes all necessary input programming and data value read outs. The Display Module design allows remote mounting at the operating or shutdown panel board of the engine. RS-485 serial communications will allow up to 350 foot distance for the remote terminal location.

1.6 The engine speed set point may be changed from the Display Module, 4 to 20 mA signal input or using the MODBUS RTU interface.

2.0 MOUNTING GOV UNIT

2.1 The gas metering valve should be inspected immediately after unpacking. Check for any damage that may have occurred during shipment. If there are any questions regarding the physical integrity of the valve, contact the Altronic distributor that supplied the Governor. If possible, keep the original shipping container. If future transportation or storage of the valve is necessary, this container will provide optimum protection.

Ensure that the GOV received matches the model no. and configuration of the fuel valve to the packing list and to the purchase order. The top plate of the GOV contains information pertinent to that particular valve, for example, flow feedback information, flange type, etc. The GOV10/50 Governors are CSA certified for Class I, Group D, Division 1 or 2 hazardous locations. See drawings 809007 and 809008.

2.2 When considering where to place the GOV Gas Engine Governor it is recommended that several issues be kept in mind:

- The valve should be located away from any extreme sources of heat. Operating ambient temperature -40°F to $+185^{\circ}\text{F}$ / -40°C . to $+85^{\circ}\text{C}$. Do not expose the Governor to temperatures higher than indicated here.
- Clean, dry natural gas must be supplied to the GOV Gas Engine Governor.
- Supply gas temperature will not have an effect on the flow of fuel through the acceptable operating temperature range of the valve (see above). The fuel gas temperature should not exceed 185°F / 85°C .
- Pressure variation in the fuel supply does not affect the gas flow through the valve, providing that the pressure does not drop below the minimum required for that fuel flow.

- 2.3 The GOV Gas Governor can be mounted in either a horizontal (preferred) or vertical position. Ideally, the installation will allow for at least 10 pipe diameters of straight pipe (15" for 1.5" piping) on the downstream side of the valve. This helps to ensure a consistent and smooth flow through the metering orifice, providing a more accurate fuel flow measurement. However, straight runs of piping to and from the valve are not required, though some performance degradation in flow meter accuracy will result. Flow measurement adjustments can be done to increase the accuracy of the flow meter once the valve has been installed. To optimize the engine's response to fuel flow changes, mount the GOV no more than 10 feet from the fuel manifold for optimum performance.

The valve is normally mounted and supported via the 4 or 8 bolt flanges, or the optional mounting plate. Threaded holes (5/16"-18) are provided on the bottom of the valve that can be used for securing the unit to a flat surface. The GOV10 is supplied with either SAE 61 series, 4-bolt flanges for 2" pipe or ANSI 8-bolt, class 300 flanges for 2" pipe. The GOV50 is available only with 2", SAE 61, 4-bolt type flanges.

- 2.4 Control gas pressure of **at least 25 PSIG** above fuel manifold pressure must be available at all times for valve actuation muscle. If fuel pressure to the GOV inlet (upstream fuel pressure) is always the required 25 PSIG above fuel manifold pressure (downstream pressure), the valve will operate with internal control gas pressure from the fuel supplied to the engine. If the required muscle gas is not available, an external gas line must be routed from an adequate gas pressure source to the valve pilot port. Control gas is normally bled to the downstream side of the valve. When using an external control gas line, the line must have a shutoff valve that closes during engine shutdown. Control gas volume required is 3 SCFM.

NOTE: GOV units require the use of External Gas Filter Kit 820001. See drawings 801011 and 809012 for installation details.

The maximum recommended regulated gas supply pressure for operation of the GOV is 75 PSIG. Depending on the application, this may have to be lower for proper light load control.

WARNING: Maximum gas pressure to the valve must never exceed 200 PSIG.

3.0 WIRING THE GOV UNIT

- 3.1 The following instructions apply to the electrical requirements of the GOV unit. All methods must conform to the applicable electrical code with regard to hazardous environment installations.

The wiring methods to be used are through threaded, rigid metal conduit with termination fittings approved for the location. The entire assembly is to be explosion-proof and to employ connections approved for Class I Division 1 or 2 as required for the installation.

CAUTION: The system power should be OFF before any of the valve wiring is connected or disconnected. Failure to do so may result in damage to your engine and/or the GOV10/50.

3.2 The GOV10/50 requires 20 to 32 Vdc, 1 amp electrical power **at the connector or harness**. Power should be steady and uninterrupted. Power dips of any duration below 20 volts may cause the GOV valves to close and to stay closed until a new start sequence is initiated.

3.3 The GOV10/50 come standard with a 3/4" NPT conduit entry. The threaded conduit entry is for use in Division 1 classified areas. In Division 1 installations, the wiring is contained in rigid threaded metal conduit per the appropriate electrical codes. The entire assembly is intended to be explosion-proof and to employ approved connection means. Wires are terminated to a terminal strip inside the GOV unit. See drawing 809014.

3.4 When installed in Class 1, Division 2 areas, which is the typical rating of an engine driven natural gas compressor application, a military connector (MS) option is available. The connector adaptor is Altronic Part Number 893003.

Screw the connector adaptor into the 3/4" NPT conduit hole and terminate the wires as shown in drawing 809020. The mating harness for the connector is CSA approved for Class I, Division 2 area use and provides a quick disconnect feature which greatly simplifies installation and maintenance. Terminate the harness in a standard junction box using an appropriate terminal strip. To adjust the harness length, see drawing 809019.

3.5 All wiring to the GOV should be of a shielded, twisted pair type. Valve wiring should be run in a separate conduit. Never run the wiring in conduit containing wires with AC service, or with wires connected in any way to the ignition system of the engine.

24Vdc power wire size is dependent on the distance from the supply to the GOV. Wires must be large enough to insure at least 20 Vdc at the GOV terminal connection. Use 16 gauge wire, Altronic P/N 503188 or equivalent.

The 4 to 20 mA wiring for remote speed demand, fuel flow feedback, and RS-485 communications wires may be up to 350 feet long. Noise is always a consideration on these signals, so the wire length should be kept as short as possible. Smaller gauge wire (20 AWG) may be used for distances under 100'.

Magnetic pickup wiring should be 22 AWG twisted pair, shielded wire with a length no longer than 50 feet. See drawing 809015 for pickup mounting detail.

3.6 The discrete output can be used as a fuel permissive and as a shutdown or malfunction signal input to the engine management system which controls the operation of the upstream block and bleed valve. When RPM exceeds the CRANK RPM setting and the purge timer expires, this contact will close representing a request for fuel supply pressure. This signal can be used as a permissive to fuel the engine. The contact will open upon any of the shutdown features programmed into the GOV including low fuel supply pressure, overspeed, high fuel manifold pressure and others listed section 7.11 of this manual. This polarity sensitive isolated discrete output has a 3 amp capability and is suitable for use in a series of switches to drive a small solenoid valve or relay.

NOTE: A separate, redundant, engine overspeed shutdown system must be provided on the engine.

3.7 When wiring a new GOV unit, or updating an existing unit of an earlier design, refer to the wiring reference chart shown in section 4.0.

4.0 WIRING CHART FOR GOV UNIT

ALTRONIC GOV REFERENCE			CCC GOV REFERENCE	
Terminal PCB Name	Connector Pin	Service Function	Pin	Wire Color
POWER(+)	A	24Vdc (+)	A	White
POWER (-)	B	24Vdc common (-)	B	Grey
DEMAND (+)	C	Remote Speed Demand 4-20mA Input (+)	C	Blue
DEMAND (-)	D	Remote Speed Demand 4-20mA Return (-)	D	White/Blue
A out 1 (+)	E	Analog Out 1 (Flow) 4-20 mA Loop Supply (+)	E	Yellow
A out 1(-)	F	Analog Out 1 (Flow) 4-20 mA Loop Return (-)	F	White/Yellow
GT MPU	G	Magnetic Pickup (A)	G	Red/Blue
GT MPU	H	Magnetic Pickup (B)	H	White/Black
A out 2 (+)	(E)	Analog Out 2 (RPM) 4-20 mA Loop Supply (+)	J	Yellow/Red
A out 2 (-)	J	Analog Out 2 (RPM) 4-20 mA Loop Return (-)	K	Yellow/Black
DSPL (+)	K	Display Comm. (+)	L	Gray/Red
DSPL (-)	L	Display Comm. (-)	M	White/Red/Gray
Aux 2 (+)	Not Used	Aux 2 (+)	N	White/Gray
D in 1 (+)	P	Discrete Input 1 (+) Force Local	P	White/Violet
D in 1 (-)	S	Discrete Input 1 (-)	S	White/Yellow/Brown
D in 2 (+)	T	Discrete Input 2 (+) Cancel WarmUp	T	White/Orange/Blue
D in 2 (-)	(S)*	Discrete Input 2 (-)	U	White/Red/Green
D out (+)	U	Discrete Output 1 (+)	V	White/Yellow/Orange
D out (-)	V	Discrete Output 1 (-)	W	White/Yellow/Red
RTU (+)	M	MODBUS Comm. (+)	Y	Green
RTU (-)	N	MODBUS Comm. (-)	Z	Brown
Aux 2 (-)	Not Used	Aux 2 (-)	a	White/Brown
Aux 1 (+)	R	Pressure transducer (+)	b	White/Red/Brown
Aux 1 (-)	(B)	Pressure transducer (-)	c	White/Green

5.0 MOUNTING THE GOV DISPLAY MODULE

- 5.1 Mount the GOV Display Module inside a control panel or to a suitable flat surface preferably off the engine in such a manner as to minimize exposure to vibration. The Display Module should be mounted so that the display is at a convenient viewing height. Refer to drawing 809016 for mounting dimensions. A NEMA 3R housing (720004-1) is also available as an alternative mounting option for the Display Module (See drawing 809018).
- 5.2 The Display Module should be mounted within 50 feet (15m) of the GOV unit which is mounted near the engine.
- 5.3 Operating temperature range of the Display Module is -40°F to 158°F (-40°C to 70°C). Humidity specification is 0 to 95%, non-condensing. Housed in an aluminum weatherproof enclosure, the GOV Display Module is splash resistant, however, the mounting site should provide as much protection from inclement weather as is practical. Avoid mounting the LCD display and keypad in direct sunlight.

6.0 DISPLAY MODULE WIRING

- 6.1 GENERAL - Take care not to damage wiring insulation and take precautions against damage from vibration, abrasion, or liquids in conduits. In addition, DO NOT run low voltage power, current loop, or communications wires in the same conduit as the ignition wiring or other high energy wiring such as AC power, etc. Keep wires at least 12 inches away from all high voltage wiring.
- 6.2 POWER - Power input to the Display Module must come from the power for the GOV unit and connect as shown in drawing 809017. DO NOT ground the Display Module directly to the common coil ground of the ignition.

IMPORTANT: To ensure that both the GOV unit and the Display Module operate at the same ground potential, it is imperative to use the “daisy chain” hookup shown on drawing 809020.

- 6.3 COMMUNICATIONS - The Display Module communicates to the GOV module via the two wire RS-485 connections. Per drawing 809017 use Altronic 4 conductor shielded cable P/N 503194-500 to connect the Display Module and the GOV Module.

7.0 UNDERSTANDING THE HOME SCREEN

- 7.1 The home screen is designed to provide indication of the current status as well as critical operational characteristics. The template for the home screen includes a text description of the current Governor state and the current control source. The template also includes numerical values for Fuel Manifold Pressure (FMP), Fuel Supply Pressure (FSP), Engine RPM and RPM setpoint target.

<i>STATUS</i>	<i>FMP</i>	<i>RPM</i>
<i>MODE</i>	<i>FSP</i>	<i>target</i>

- 7.2 An example of the home screen below depicts an engine running at 300 RPM with a Fuel Manifold Pressure of 29.5 PSIG. The lower line indicates that the LOCAL speed target of 300 RPM is in force, and the Fuel Supply Pressure is 55.0 PSIG.

RUN	29.5	300
LOCAL	55.0	300

Definitions of the status words, and conditions are provide below:

- READY Engine is Stopped, and conditions are ready to start.
- NOTRDY Engine is Stopped, but FMP or FSP are above the ready setpoints.
- ROTATE Engine Rotation is detected, but speed is too slow to begin purging.
- PURGE Engine is rotating with fuel off to purge cylinders of residual fuel.
- PURGED Engine is now purged, digital output is on, waiting for FSP.
- START Engine is being fueled to start based on a pressure control schedule.
- WARMUP Engine RPM indicates combustion, speed control target is Minimum Speed.
- RUN Warmup Period Complete, Control Engine Speed to Control Target.
- SHUTDN The engine is being shutdown, will persist 30 sec after 0 rpm reached.
- FAULT A Governor system fault was detected. Diagnose the cause before starting.

7.3 An example of the home screen below depicts the stopped engine READY condition with the Fuel Manifold Pressure blown down reading 0.0 PSIG and the Fuel Supply Pressure blown down reading 0.1 PSIG. The lower line indicates that the demand current loop speed target of 300 will be in force after warmup is completed.

```

READY  0.0  0
LOOP   0.1  300
  
```

Definitions of the control MODE words are provided below:

- LOCAL Local Engine Speed Setpoint is active. All remote speed control sources are disabled when OFF is chosen in the Remote Control setup screen.
- LOCAL+ Local Engine Speed Setpoint override is active. Remote speed control sources permitted when ON is chosen in the Remote Control setup screen, will be overridden by energizing digital input 1 which forces local mode control.
- LOCAL* Local Engine Speed Setpoint default is active. Remote speed control sources permitted when ON is chosen in the Remote Control setup screen, will revert to the Local speed setting when the loop input is out of range and MODBUS RTU input register is not being written.
- LOOP Remote Speed Setpoint based on Demand Current Loop Input is active.
- MODRTU Remote Speed Setpoint MODBUS RTU register is valid and being updated every second.
- ###SEC Wait time remaining in PURGE, PURGED and WARMUP states.

7.4 The home screen examples below depict the stopped engine NOT READY condition that indicates that FMP or FSP is above the configured READY pressure thresholds. When the pressure is above the ready threshold, the > symbol, as well as the threshold, are displayed. The “not ready” message indicates that it is not safe to attempt a start because fuel pressures are higher than expected for the engine stopped condition.

```

NOTRDY  6.2> 2.5
LOCAL   0.1  300
  
```

Fuel Manifold Pressure too high

```

NOTRDY  0.0  0
LOCAL   5.1> 3.0
  
```

Fuel Supply Pressure too high

```

NOTRDY  6.2> 2.5
LOCAL   5.1> 3.0
  
```

Both FMP and FSP too high

- 7.5 The ROTATE screen example below will be presented when rotation below the Crank RPM setpoint is detected. The engine is turning but the speed is not sufficient to begin the purge cycle. If the speed drops back to zero, the state will return to Ready.

```
ROTATE  0.0  13
LOOP    0.1  300
```

- 7.6 The PURGE cycle is started when the RPM is above the Crank RPM setpoint. The time remaining in the purge cycle is displayed on the lower left. The run speed target of 300 RPM is still displayed, and will be the speed target after completion of warmup. The purge timer will be restarted if the speed drops below the Crank RPM setpoint. The start attempt will be terminated if the FMP (Fuel Manifold Pressure) is seen as being above the ready threshold.

```
PURGE   0.0  63
3sec    0.1  300
```

- 7.7 The PURGED state display indicates that the PURGE cycle is complete and the fuel request output has been activated. Control will wait in the PURGED state while waiting for sufficient FSP (Fuel Supply Pressure). If the fuel supply is not seen within the FSPabortsec (seconds) setpoint, then the start will be aborted. On this screen the actual fuel supply threshold FSP minimum is also shown after the < sign indicating there is insufficient fuel supply pressure.

```
PURGED  0.0  65
11sec   1.1<50.0
```

- 7.8 The START state display indicates that the Governor has a proper fuel supply and is working to fuel the engine to obtain Light-Off. The start attempt will be complete when the engine speed rises above the Start RPM setpoint now shown in lower right corner of display. The start attempt will terminate if not started within the Start Seconds setpoint or if the fuel manifold pressure goes above the Hi Start FMP setpoint.

```
START   14.3  75
6sec    55.2  150
```

7.9 The WARMUP state display indicates that the engine is running and the transition from start fueling to constant speed control has been made. The warmup period will last for the Warmup Seconds setting at which point the active speed target will become the run speed target. During warmup, the engine runs at the Minimum RPM setpoint selected in the engine configuration.

```
WARMUP 14.3 75
        6sec 55.2 220
```

7.10 The RUN state will be the most familiar screen and indicates that the engine is running, as well as indicating the Fuel Manifold Pressure, the current engine RPM, the source of the speed target, the Fuel Supply Pressure, and the target setpoint RPM.

```
RUN      29.5 300
LOCAL   55.0 300
```

7.11 Once running, the only state that the Governor can change to is the shutdown (ShutDN) state. Several causes of shutdown are possible, with the most common shown below indicating low Fuel Supply Pressure, which is the “Normal Shutdown Method”. Typically the engine operator, or the safety shutdown system, will turn off the supply of fuel to the engine to cause a shutdown. The shutdown screen state will persist until the engine speed has been zero for 3 seconds at which time the state will transition to READY or NOT READY.

```
ShutDN 0.5 121
STOP=LoFSP
```

Examples of all the shutdown causes are listed below:

- STOP = LoFSP indicates normal shutdown or low supply pressure
- STOP = HiFMP indicates overload condition by pressure
- STOP = OvrSPD indicates an overspeed condition caused the shutdown
- STOP = LoRPM indicates a stall or loss of pickup signal
- STOP = HiSCFM indicates overload condition in relation to fuel HP
- STOP = HiSCFR indicates overload condition in relation to fuel torque
- STOP = WaitFSP indicates a stop due to FSP timeout
- STOP = StartTIME indicates that start was aborted due to timeout
- STOP = AbortFMP indicates that start was aborted due to FMP above AbortFMP
- STOP = sawFSP indicates that FSP was above FSPrdy before PURGED
- STOP = sawFMP indicates that FMP was above FMPrdy before START cycle
- STOP = FAULT indicates a Governor or Governor system fault
- POWERUP indicates no rotation since power up

8.0 DISPLAY VALUES SCREENS

8.1 The Governor provides screens for display of values relating to various measured or calculated values of interest to the operator. These display screens can be viewed from the home screen using the up and down arrow keys to rotate the screens forward or backward.

```
RUN      22.0  300
LOCAL    60.0  300
```

press to
display
next
value

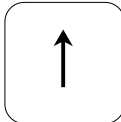

press to
display
previous
value

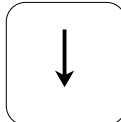

```
RUN      22.0  300
FMP_PSIG = 22.00
...
FSP_PSIG = 60.00
FCP_PSIG = 35.00
AMP_inHg = 13.20
ACT_cnts  = 2025
ACT_PSI   = 13.00
Aux1_mA   = 10.00
Aux2_mA   = 10.00
DemandRPM = 250
Demand_mA = 17.05
FuelTemp  = 78°F
DeltaPSI  = 1.24
Flow_SCFM = 314
Flow_SCFR=0.2184
```

9.0 SETUP SCREENS

- 9.1 There are two levels of USER adjustable variables in the GOV system. The first level is referred to as the SETUP screens. These are values and options which are commonly adjusted when the engine is in use. To access these values a simple press of the SETUP key is all that is required.

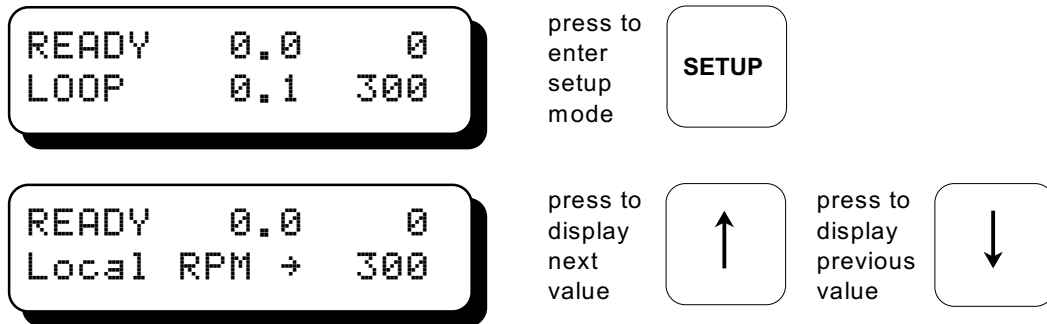

**The arrow always points to the adjustable value on the SETUP screen.
Adjustments to SETUP values are saved instantly and retained until changed again.**

- 9.2 Adjust the local RPM setpoint, this is the speed the engine will run when the local control from the Display Module is active. The GOV will start controlling to this setpoint when the warmup timer expires.

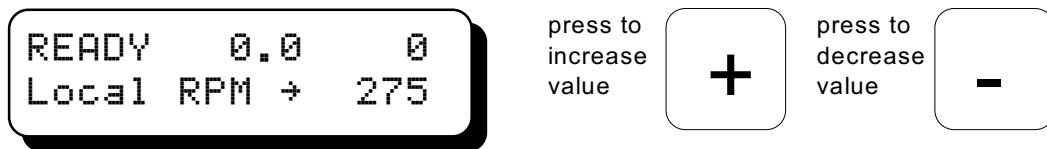

- 9.3 Enable remote control of RPM, toggles OFF/ON with the +/- keys. Selecting OFF disables remote control of the speed setpoint. Selecting ON enables remote control either by a valid 4-20ma input demand current loop signal or by repetitive writes to the MODBUS speed setpoint register.

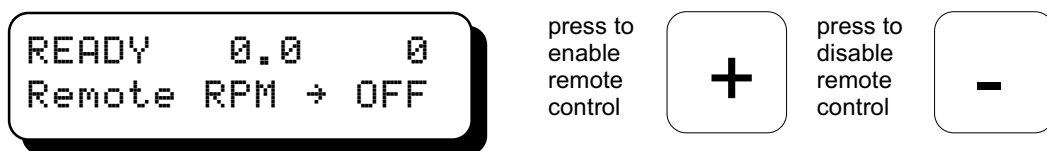

- 9.4 Use the + key to cancel the warmup timer from this screen. This function can also be accomplished remotely by momentarily energizing digital input 2.

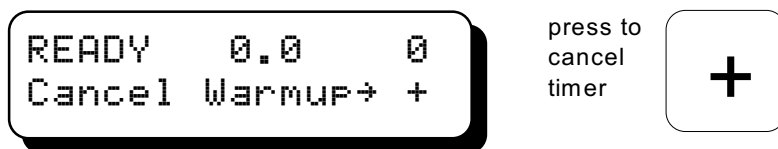

- 9.5 Adjust the RPM DAMP value to change the filter applied to the displayed RPM value. A setting of 0 is no filtering, 254 is maximum filtering. Factory default is 240.

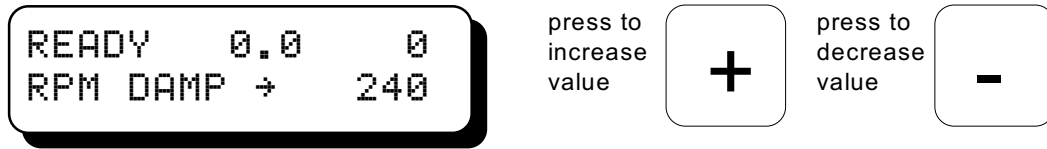

10.0 CONFIGURATION SCREEN OVERVIEW

- 10.1 The second set of USER adjustable values are called CONFIGURATION screens. These values must be programmed prior to running the engine. These values are rarely adjusted in normal use and should be accessed only by qualified personnel; they therefore require a special key sequence.

Beginning at the HOME screen

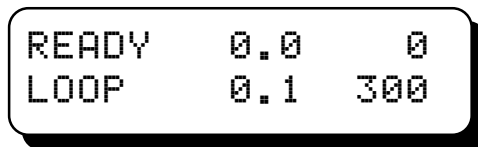

- 10.2 The CONFIGURATION values are broken up into groups of settings related by function. The group name appears on the top line of the display. The groups are: *Start Config*, *Start Control*, *RPM Control*, *Flow Config*, *Engine Config*, *Sensor Config*, *Hardware Config* and *Analog OUT Config*. When in the CONFIGURATION mode, the SETUP key can be used to move between the groups. The groups are arranged to have the most frequently changed parameter groups located first in the group rotation.

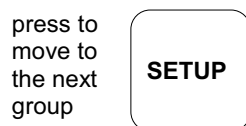

10.3 The arrow keys are used to move between the CONFIGURATION screens within each group.

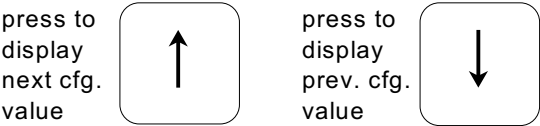

10.4 The + and - keys are used to increase and decrease the configuration value.

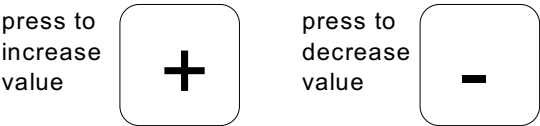

The right arrow always points to the adjustable value on the CONFIGURATION screen. Adjustments to CONFIG values are saved instantly and retained until changed again.

11.0 CONFIGURATION SCREENS FOR THE START CONFIG VARIABLES GROUP

11.1 Program the Start RPM, this is the RPM at which the engine is self-sustaining, often referred to as the “light off” RPM. After this RPM is reached, the GOV will transition from Start Control to RPM Control, and it will ramp the engine RPM to the Minimum Speed. This setting should be greater than the fastest cranking RPM and less than the minimum RUN RPM.

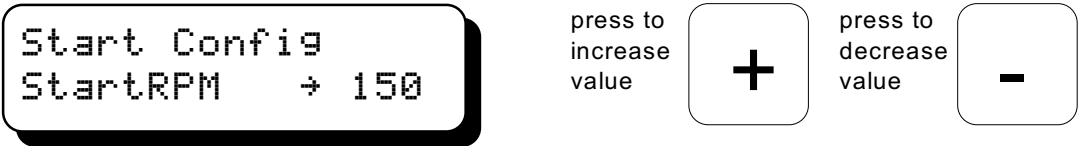

11.2 The Start Fuel Manifold Pressure is the desired fuel pressure in PSIG at start up. The GOV will control the fuel manifold pressure based on this value until the START RPM is reached.



Or the Start Fuel SCFR flow rate desired for start up in SCFR mode. The start mode is selected under the Engine Config menu (15.12). Note, this setting is new for version 2.0.



- 11.3 The Ramp Fuel Manifold Pressure feature can be used to ramp fuel pressure during startup. The value shown below will add 0.10 PSI of start fuel pressure for each second in start mode. The Fuel Manifold Pressure will ramp upwards until the engine starts or until the maximum start pressure (LimitFMP) is reached. Not present in SCFR start mode.



- 11.4 The optional AMPbias setting will add to the fuel pressure vs AMP in PSIG/inHG. When starting in the FMP mode this allows the pressure target to follow the air manifold pressure as it may change during the start. To use this feature an external AMP sensor must be used. This setup value is not present in the SCFR start mode.



- 11.5 Set the Maximum Fuel Manifold Pressure target in PSIG allowed for starting. Use this value to cap a ramping or biased start pressure schedule to the desired limit for starting. This setup value is not present in the SCFR start mode.



- 11.6 Set the Maximum Fuel Manifold Pressure PSIG allowed for starting. Use this value to establish a maximum pressure above which a start should be aborted. New for V2.0.



- 11.7 Set the Maximum Time in seconds to keep fueling in START mode before abort of start attempt.

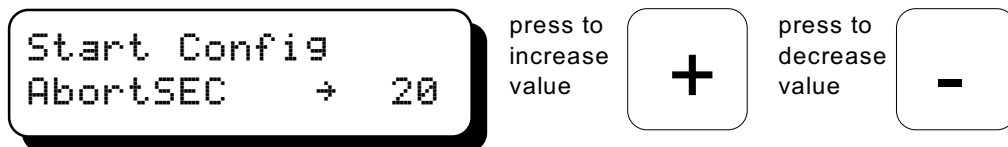

- 11.8 Set the Maximum time after PURGED to wait for supply pressure before abort of start attempt.



12.0 CONFIGURATION SCREENS FOR THE START CONTROL VARIABLES GROUP

- 12.1 Set the value of PSIG error for the maximum control response from GOV to be implemented. In SCFR start control mode, this value is named MaxErrSCFR (new for v2.0).



- 12.2 Set the fastest rate at which the GOV will try to change the start fuel pressure to maintain the setpoint in PSI/SEC. In SCFR start control mode, this value is named MaxRateSCFR.



- 12.3 Set the limit for PSI/SEC error term to restrict control response in an extreme transient. Typically, double the MaxPSIRate setting. Named RateLimSCFR in SCFR start mode.



- 12.4 The GainPSI setting determines the response of the start fuel PSI control loop. Higher values cause a greater response to psi/sec errors. Each step between 1 and 255 produces an effective 2% change in the control gain. Typical values are 125 to 200. Higher gain values are typical for engines of larger horsepowers and operating pressures. In SCFR start mode the gain value is called GainSCFR.



- 12.5 Reset Rate for PSI/SEC control determines the time to integrate the full proportional response of the system in seconds (0.01 to 9.99). Adjust this value to compensate for fuel manifold volume and flow rates. Larger manifolds tend to require longer reset rates while higher flow applications may require a shorter reset rate. Typical values are 0.10 to 1.00. In SCFR start mode the reset rate value is called RstRateSCFR.



12.6 Set Actuator Kick counts to tailor the initial valve opening characteristic for the engine application. This value represents the initial actuator output counts when first opening the valve. Engine application and valve hardware tolerances are compensated by this parameter (0-1000).



13.0 CONFIGURATION SCREENS FOR THE RPM CONTROL VARIABLES GROUP

13.1 The Altronic GOV uses a proprietary approach to engine speed control which has been optimized for gas fueled engines. Typical Governors, when applied to gas engines, use a dual loop or dual rate approach to avoid problems in RPM control caused by the difference in engine behavior between unloaded and loaded conditions. When the gas engine is unloaded it often suffers from misfire. When a gas engine misfires, the torque produced by the cylinder which was intended to fire disappears regardless of the amount of fuel being delivered. The Governor, which after all is only sensing the engine RPM, will naturally try to increase the fueling rate of the engine because the speed is dropping. When an engine is misfiring, however, the next firing will often occur normally, causing a speed increase even without the Governor increasing the fueling rate. When fueling after the misfire is increased by the Governor, as normally occurs, the next firing causes much more acceleration than intended, so that the RPM is quickly above the desired value. This occurs even though the engine was below the setpoint value as a result of the misfire, only a single firing earlier.

Unfortunately, when the engine is unloaded, almost every firing (regardless of the fueling rate) has the potential to increase engine speed significantly. Additionally, because the engine is unloaded, the forces available to cause deceleration of the engine are at a minimum. The combination of these effects result in the poor speed stability of the engine when unloaded and a tendency to overspeed. Conversely, when a gas engine is loaded, forces acting in a manner to decelerate the engine are at a maximum and the firing of every cylinder at the current fueling rate is normally required just to maintain the engine RPM. When the engine is fully loaded, the forces available to cause the engine to accelerate are at a minimum. Loaded engines therefore are inclined to droop in speed or lug when experiencing a load increase.

In order to moderate these effects, the Altronic GOV monitors the acceleration and deceleration of the engine at all times, and depending upon the magnitude of the RPM error from the setpoint and a set of user-tuned variables, calculates a currently desired acceleration or deceleration rate. The desired rate of acceleration or deceleration for a given engine is the same for different load conditions, but the fueling adjustment needed to cause the desired rate change when loaded or unloaded is quite different. By comparing the measured acceleration to that which is desired for a given RPM error, the GOV can implement a fueling change based upon the likelihood of its actually being needed to achieve the RPM setpoint in a timely manner. This operating philosophy allows for a common set of tuning variables to control both an unloaded and a loaded engine.

- 13.2 AccLimRPM is used to limit the magnitude of RPM error used in the governor control logic. It provides a means to deliver aggressive control response when RPM error is small by limiting the error input signal when RPM error is large. The control output response will increase proportionally to the size of the error until the magnitude of the error is limited by AccLimRPM. The recommended value of 40 has been observed to work best on most engines. Limit the range of this setting between 20 and 60.



- 13.3 MaxAccRate determines the maximum desired acceleration or deceleration target rate at which to seek the target RPM. Higher values will cause the Governor to seek the target speed at a faster rate. The actual acceleration target is established ratio-metrically from MaxAccRate based on the RPM error. As RPM error would go from AccLimRPM to zero, the acceleration target would go from MaxAccRate to zero. The recommend value of 40.00 RPM/SEC has been observed to work best on most engines. The range of this setting should be limited between 5 and 50 RPM/SEC.



- 13.4 AccErrLim is used to limit the magnitude of observed engine acceleration that is used in the calculation of acceleration error. Decreasing the value results in less derivative control action, while increasing the value results in more. Set this value at 50% of MaxAccRate for best balanced control response.



- 13.5 The GainAccel setting determines the response of the Governor to the error in acceleration and speed which has been computed for the last revolution based on the above settings. Higher values cause a greater actuator response to acceleration errors. Each step between 1 and 255 produces an effective 2% change in the control gain. Typical values are 50 to 150. Higher gain values are typical for engines of larger horsepowers and operating pressures.



- 13.6 Reset Rate for acceleration control determines the time to integrate the full proportional response of the system in seconds (0.01 to 9.99). Adjust this value to compensate for fuel manifold volume and flow rates. Larger manifolds tend to require longer reset rates while higher flow applications may require a shorter reset rate. Typical values are 0.10 to 1.00

- 13.7 If actual engine speed is above the speed setpoint by more than 15% of (Overspeed minus Setpoint), then aggressive actions to reduce the engine speed are enabled. The recommend value is 15% and it is adjustable from 1% to 50%.

14.0 CONFIGURATION SCREENS FOR THE FLOW VARIABLES GROUP

- 14.1 This scalar value should be calibrated while running with a known SCFM from a calibrated flow meter. Note: The typical range of the value is lower for version 2.0 firmware.

- 14.2 This value should be calibrated to read -32 DP counts with engine off and DP_AZ (auto zero) turned off.

- 14.3 The auto zero feature is new for firmware V2.0 and can be enabled or disabled on this screen. Automatic zero of DP counts will be active when turned on with GOV in the Ready state and all pressure sensors within 2.5 psi of zero.

14.4 Excessive Fuel Flow shutdown, should be set to ~110% of the fuel flow SCFM measured with engine running at max HP.

A screenshot of a control menu titled "FlowCFG". The second line shows "SCFM SD" followed by a right-pointing arrow and the value "250". To the right of the menu are two buttons: a "+" button labeled "press to increase value" and a "-" button labeled "press to decrease value".

14.5 Excess fuel flow per revolution, should be set to ~125% of SCFR measured at maximum allowable engine torque load. Note: The resolution of this value has changed in v2.0. Use 6.5535 to disable this feature.

A screenshot of a control menu titled "FlowCFG". The second line shows "SCFR SD" followed by a right-pointing arrow and the value "1.1250". To the right of the menu are two buttons: a "+" button labeled "press to increase value" and a "-" button labeled "press to decrease value".

14.6 Minimum duration of transient events in seconds before SCFM or SCFR shutdown is implemented.

A screenshot of a control menu titled "FlowCFG". The second line shows "SCFxSDsec" followed by a right-pointing arrow and the value "5". To the right of the menu are two buttons: a "+" button labeled "press to increase value" and a "-" button labeled "press to decrease value".

15.0 CONFIGURATION SCREENS FOR THE ENGINE VARIABLES GROUP

15.1 The minimum RPM which can be requested when running, this applies to all setpoint sources, local, remote or Modbus. Set this to the lowest RPM allowed at site.

A screenshot of a control menu titled "Engine Config". The second line shows "MinRPM" followed by a right-pointing arrow and the value "200". To the right of the menu are two buttons: a "+" button labeled "press to increase value" and a "-" button labeled "press to decrease value".

15.2 The maximum RPM, which can be requested when running, this applies to all setpoint sources, local, remote or Modbus. Set this to the highest RPM allowed at site.

A screenshot of a control menu titled "Engine Config". The second line shows "MaxRPM" followed by a right-pointing arrow and the value "300". To the right of the menu are two buttons: a "+" button labeled "press to increase value" and a "-" button labeled "press to decrease value".

- 15.3 The RPM which will trip the output switch of the GOV and cause an engine shutdown. The engine overspeed setting.

NOTE: A separate, redundant, engine overspeed shutdown system must be provided on the engine.

Engine Conf19
OverspdRPM → 330

press to increase value

+

press to decrease value

-

- 15.4 The minimum RPM required to try for a purge and start sequence. Set at ~50% of normal cranking speed.

Engine Conf19
CrankRPM → 40

press to increase value

+

press to decrease value

-

- 15.5 The number of gear teeth sensed by the magnetic pickup.

Engine Conf19
GearTeeth → 360

press to increase value

+

press to decrease value

-

- 15.6 The length of time in seconds to crank with the fuel off before fueling.

Engine Conf19
PurgeSEC → 5

press to increase value

+

press to decrease value

-

- 15.7 The length of time to remain at the minimum allowed RPM before going to the current RPM setpoint.

Engine Conf19
WarmupSEC → 30

press to increase value

+

press to decrease value

-

- 15.8 The minimum fuel supply pressure in PSIG for running the engine. If the pressure drops below this setting, the GOV will cause a shutdown and readout LoFSP.

Engine Conf19
FSPshutdn → 60.00

press to increase value

+

press to decrease value

-

15.9 The maximum fuel manifold pressure in PSIG allowed at any time. If the fuel manifold pressure exceeds this value the GOV will cause a shutdown and readout HiFMP.

Engine Config
FMPshutdn → 40.00

press to increase value

+

press to decrease value

-

15.10 The max. fuel supply pressure in PSIG prior to a start which will allow a READY condition for the GOV. If the supply pressure to the GOV is greater than this value then the GOV will readout NotRDY and inhibit starting.

Engine Config
FSPready → 3.00

press to increase value

+

press to decrease value

-

15.11 The maximum Fuel Manifold Pressure in PSIG prior to a start to allow a READY state.

Engine Config
FMPready → 2.00

press to increase value

+

press to decrease value

-

15.12 Select the FMP or SCFR mode of starting. FMP mode controls the fuel manifold pressure. SCFR controls fuel flow in Standard Cubic Feet per Revolution. New in v2.0.

Engine Config
StartType → FMP

press to toggle setting

+

press to toggle setting

-

16.0 CONFIGURATION SCREENS FOR THE SENSOR VARIABLES GROUP

- 16.1 The span adjust for the internal Fuel Supply Pressure has a factory default of 260.00 PSI. The zero adjust for the internal Fuel Supply Pressure has a factory default of 0.00 PSI. Auto Zero Compensation of up to 2.5 psi can be enabled when the GOV is in the ready state and all sensors are indicating pressures within 2.5 psi of zero. The auto zero function added in version 2.0 firmware can be enabled or disabled as shown below.

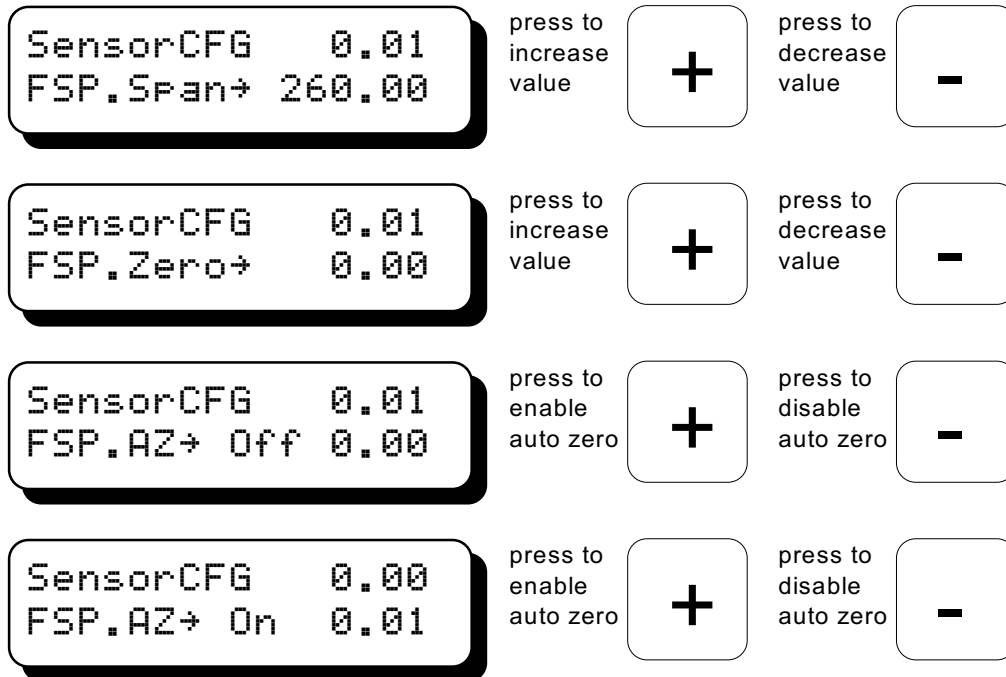

- 16.2 The span adjust for the internal Fuel Manifold Pressure has a factory default of 260.00 PSI. The zero adjust for the internal Fuel Manifold Pressure has a factory default of 0.00 PSI. The auto zero function added in version 2.0 firmware can be enabled or disabled.

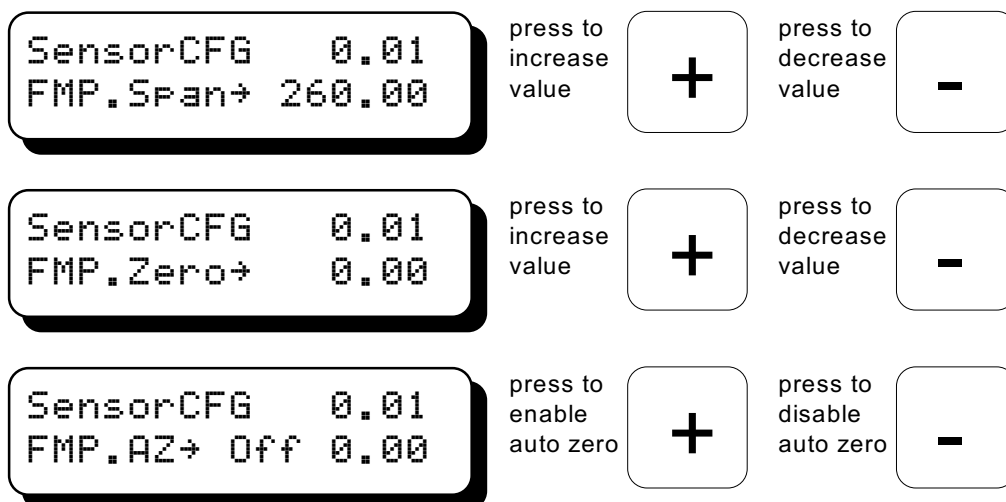

- 16.3 The span adjust for the internal Fuel Control Pressure has a factory default of 260.00 PSI. The zero adjust for the internal Fuel Control Pressure has a factory default of 0.00 PSI. The auto zero function added in version 2.0 firmware can be enabled or disabled.

SensorCFG 0.01 FCP.Span→ 260.00	press to increase value	+	press to decrease value	-
SensorCFG 0.01 FCP.Zero→ 0.00	press to increase value	+	press to decrease value	-
SensorCFG 0.01 FCP.AZ→ Off 0.00	press to enable auto zero	+	press to disable auto zero	-

- 16.4 Span and Zero calibrations are provided for an optional external Air Manifold Pressure sensor connected to Aux. Analog input #1. This sensor, typically calibrated in HG, has a span range of 0 to 655.55 and a zero range of -327.68 to 327.67. Calibrations vary based on the sensor used.

SensorCFG 0.01 AMP.Span→ 100.00	press to increase value	+	press to decrease value	-
SensorCFG 0.01 AMP.Zero→ -10.00	press to increase value	+	press to decrease value	-

17.0 CONFIGURATION SCREENS FOR THE HARDWARE VARIABLES GROUP

- 17.1 The node number to be used for Modbus RTU communications, 1 to 250 range.

Hardware Config RTU Node → 1	press to increase value	+	press to decrease value	-
---------------------------------	-------------------------------	---	-------------------------------	---

17.2 The communications Baud rate to be used.



17.3 When the actuation pressure is above the starve percent of available actuation pressure, increases to actuator output will not be permitted in order to avoid a control windup condition. This will occur when the fuel supply to the Governor is insufficient to provide the fuel flow required to obtain or maintain the desired engine speed. Upper limit extended to 150 in firmware version 2.0.



17.4 When the Governor actuation pressure is above this PA Max setting, increases to the actuator output will not be permitted in order to avoid a control windup condition. This is only possible if the control pressure source is not the same as the Gov fuel supply.



17.5 Offset to convert from PSIA to PSIG based on elavation of location. This default value is used when the on-board atmospheric pressure sensor is out of range or not available.



18.0 CONFIGURATION SCREENS FOR ANALOG OUTPUT VARIABLES GROUP

18.1 Modbus register number mapped to analog output #1. See register list on GOV CD disc. The default setting of Register 30033 points to the fuel flow in SCFM.



Note: Register 30033 SCFM is defined as an unsigned integer. To properly manage a signed register such as FMP 30025, it must be called out instead as 31025 which will configure the logic to handle the data as a signed value.

18.2 Value in selected register for analog #1 which corresponds to minimum output current of loop. The default setting of 0 represents the low limit of the SCFM register value to transmit.

AnalogOut#1 CFG
Reg.Min → 0

press to increase value  press to decrease value 

18.3 Value in selected register for analog #1 which corresponds to maximum output current of loop. The default setting of 500 represents the high limit of the SCFM register value to transmit.

AnalogOut#1 CFG
Reg.Max → 400

press to increase value  press to decrease value 

18.4 Minimum current output for value selected above in section 18.2; default is 4.0 ma.

AnalogOut#1 CFG
mA.Min → 4.00

press to increase value  press to decrease value 

18.5 Maximum current output for value selected above in section 18.3; default is 20.0 ma.

AnalogOut#1 CFG
mA.Max → 20.00

press to increase value  press to decrease value 

18.6 The adjustable output filter constant can be used to add stability to the current loop output signal. The range is 0 to 254 and more dampening is obtained with increasing settings. New in V2.0.

AnalogOut#1 CFG
mA.Damp → 1

press to increase value  press to decrease value 

18.7 Modbus register number mapped to analog output #2. See register list on GOV CD disc. The default setting of Register 30012 points to the engine speed in RPM.

AnalogOut#2 CFG
Register → 30012

press to increase value  press to decrease value 

Note: Register 30012 RPM is defined as an unsigned integer. To properly manage a signed register such as FMP 30025, it must be called out instead as 31025 which will configure the logic to handle the data as a signed value.

18.8 Value in selected register for analog #2 which corresponds to minimum output current of loop. The default setting of 0 represents the low limit of the RPM register value to transmit.

	press to increase value		press to decrease value	
--	-------------------------	--	-------------------------	--

18.9 Value in selected register for analog #2 which corresponds to maximum output current of loop. The default setting of 400 represents the high limit of the RPM register value to transmit.

	press to increase value		press to decrease value	
--	-------------------------	--	-------------------------	--

18.10 Minimum current output for value selected above in section 18.7; default is 4.0 ma.

	press to increase value		press to decrease value	
--	-------------------------	--	-------------------------	--

18.11 Maximum current output for value selected above in section 18.8; default is 20.0 ma.

	press to increase value		press to decrease value	
--	-------------------------	--	-------------------------	--

18.12 The adjustable output filter constant can be used to add stability to the current loop output signal. The range is 0 to 254 and more dampening is obtained with increasing settings. New in V2.0.

	press to increase value		press to decrease value	
--	-------------------------	--	-------------------------	--

GOV10 Modbus Register List 04/26/06 Release version 2.0

```
#####  
# read permitted only in blocks of 8 #  
# example: 00001 through 00008 #  
#####  
00001 "Local/Remote RPM Target 0=Loc "  
00002 "ROI active on RTU port 1=ON "  
00003 "FMP Auto Zero Bit 1=ON "  
00004 "FSP Auto Zero Bit 1=ON "  
00005 "FCP Auto Zero Bit 1=ON "  
00006 "DP Auto Zero Bit 1=ON "  
00007 "RESERVED "  
00008 "RESERVED "  
#####  
# read permitted only in blocks of 8 #  
# examples:00001 through 00008 #  
# 00001 through 00040 #  
# 00033 through 00040 #  
#####  
10001 "Control Pressure Low "  
10002 "Control Pressure High "  
10003 "Outlet Pressure Low "  
10004 "Outlet Pressure High "  
10005 "Supply Pressure Low "  
10006 "Supply Pressure High "  
10007 "Delta P Low "  
10008 "Delta P High "  
10009 "Barometric Pressure Low "  
10010 "Barometric Pressure High "  
10011 "Fuel Temperature Low "  
10012 "Fuel Temperature High "  
10013 "Demand (ma) Signal Low "  
10014 "Demand (ma) Signal High "  
10015 "RESERVED "  
10016 "RESERVED "  
10017 "Auxiliary #1 (ma) Signal Low "  
10018 "Auxiliary #1 (ma) Signal High "  
10019 "Auxiliary #2 (ma) Signal Low "  
10020 "Auxiliary #2 (ma) Signal High "  
10021 "RESERVED "  
10022 "RESERVED "  
10023 "RESERVED "  
10024 "RESERVED "  
10025 "3.3V Power Supply Low "  
10026 "3.3V Power Supply High "  
10027 "5V Power Supply Low "  
10028 "5V Power Supply High "  
10029 "10V Power Supply Low "  
10030 "10V Power Supply High "  
10031 "24V Power Supply Low "  
10032 "24V Power Supply High "  
10033 "Braking "  
10034 "Act. Max Authority Reached "  
10035 "FSP Max Authority Reached "  
10036 "Digital Input #1 Energized "  
10037 "Digital Input #2 Energized "  
10038 "Digital Output Energized "  
10039 "EEPROM Value Change Detected "  
10040 "FMP Start Limit Active "
```

```

#####
# INPUT REGISTERS 30xxx #
# RANGE 1 TO 100 REGISTERS PER REQUEST #
#####
30001 "mirror of inputs 10016-10001 "
30002 "mirror of inputs 10032-10017 "
30003 "mirror of inputs 10048-10033 "
30004 "mirror of inputs 10064-10049 "
30005 "mirror of inputs 10080-10065 "
30006 "mirror of inputs 10096-10081 "
30007 "mirror of inputs 10112-10097 "
30008 "mirror of inputs 10128-10113 "
30009 "GOV10 status NOW "
30010 "Current state timer if present" unsigned
30011 "Engine Acceleration RPM/sec " signed
30012 "Engine Speed RPM Filtered " unsigned
30013 "Engine Speed RPM*10 NOW " unsigned
30014 "Speed target NOW " unsigned
30015 "RPM error (rpm-sp) NOW RPM " signed
30016 "Acceleration Target NOW " signed
30017 "Acceleration error NOW " signed
30018 "START rate NOW " signed
30019 "START target sp NOW " unsigned
30020 "Start error NOW " signed
30021 "START rate sp NOW " signed
30022 "START rate err NOW " signed
30023 "Actuator Counts NOW " unsigned
30024 "Supply Pressure psig *100 " signed
30025 "Manifold Pressure psig *100 " signed
30026 "Control Pressure psig *100 " signed
30027 "Actuator Pressure psi *100 " signed
30028 "Delta Pressure psi *100 " signed
30029 "Delta Pressure A/D counts" unsigned
30030 "Baro(sys)Pressure psi *100 " signed
30031 "Baro(sen)Pressure psi *100 " signed
30032 "Fuel Temp deg K *10 " unsigned
30033 "Fuel Flow SCFM " unsigned
30034 "Fuel Flow / RPM SCFR*10000" unsigned v2.0 scale
30035 "SCFx SD seconds sec * 10" unsigned
30036 "Demand Signal Input mA * 100" unsigned
30037 "Demand Signal Setpoint RPM " unsigned
30038 "Aux 1 Signal Input mA * 100" unsigned
30039 "Air Manifold Pressure inHg*100" signed
30040 "FMP per AMP bias PSI/inHg*100" unsigned
30041 "Aux 2 Signal Input mA * 100" unsigned
30042 "Aux 2 Signal Input si units" signed
30043 "Aux 1 Signal Output mA * 100" unsigned
30044 "Aux 2 Signal Output mA * 100" unsigned
30045 "FMP AutoZero Offset psig *100" signed
30046 "FSP AutoZero Offset psig *100 " signed v2.0 new
30047 "FCP AutoZero Offset psig *100 " signed v2.0 new
30048 "DP AutoZero Offset counts " signed v2.0 new
; \ / updated upon GOVstat change to STOPPING \ /
30049 "STOP decision " unsigned
30050 "GOV10 status at STOP decision " unsigned
30051 "Engine Speed at STOP decision " unsigned
30052 "Engine Accel at STOP decision " signed
30053 "Speed target at STOP decision " unsigned
30054 "Press target at STOP decision " signed
30055 "FSP psig at STOP decision " signed
30056 "FMP psig at STOP decision " signed
30057 "FCP psig at STOP decision " signed

```

```

30058 "Delta psig at STOP decision " signed
30059 "Fuel Temp at STOP decision " unsigned
30060 "Fuel Flow at STOP decision " unsigned
30061 "Fuel Flow/R at STOP decision " unsigned
; /\ updated upon GOVstat change to STOPPING /\
30070 "GOV VOLTAGE 24V volts *10 " unsigned
30071 "GOV VOLTAGE 10V volts *10 " unsigned
30072 "GOV VOLTAGE 5.0V volts *10 " unsigned
30073 "GOV VOLTAGE 3.3V volts *10 " unsigned
30074 "FSP Voltage volts *100" unsigned
30075 "FMP Voltage volts *100" unsigned
30076 "FCP Voltage volts *100" unsigned
30077 "Baro Voltage volts *100" unsigned
30078 "Delta Voltage volts *100" unsigned
30079 "Fuel Temp Voltage volts *100" unsigned
#####
# READ/WRITE REGISTERS 40xxx #
# RANGE 1 TO 100 REGISTERS PER REQUEST #
#####
40001 "mirror of coils 00016-00001 " bitflags
40002 "mirror of coils 00032-00017 " bitflags
40003 "mirror of coils 00048-00033 " bitflags
40004 "mirror of coils 00064-00049 " bitflags
40005 "mirror of coils 00080-00065 " bitflags
40006 "mirror of coils 00096-00081 " bitflags
40007 "mirror of coils 00112-00097 " bitflags
40008 "mirror of coils 00128-00113 " bitflags
Type(byte)= 128(signed)+64(2bytes)+4(nochangeModBus)+2(reg limits)+1(nochange running)
** Setup ** {type,Min,Max } {Default}
40009 "Local Speed RPM setpoint " {2,40030,40031} DEF={ 250}
40010 "RPM Dampener 0-254 0=No Filter" {0,00000, 254} DEF={ 240}
** Start Config ** {type,Min,Max } {Default}
40011 "Start Speed (begin gov) " {0,00000, 3000} DEF={ 150}
40012 "Start base FMP PSIG*100" {0,00000, 5000} DEF={ 500}
40013 "Start ramp FMP PSI/SEC*100" {0,00000, 200} DEF={ 0}
40014 "Start bias AMP 0-10.00*100" {0,00000, 1000} DEF={ 000}
40015 "Start limit FMP PSIG*100" {0,00000, 5000} DEF={ 2500}
40016 "Start abort Seconds 0-999s" {0,00000, 999} DEF={ 10}
40017 "Wait for FSP sec 0-999s" {0, 0, 999} DEF={ 20}
** Start Control ** {type,Min,Max } {Default}
40018 "START Max PSI Rate PSI*100/s" {0, 5, 9999} DEF={ 500}
40019 "START PSI Err Lim PSI*100" {0, 5, 9999} DEF={ 1000}
40020 "START Rate Lim PSI PSI*100/s" {0, 50, 9999} DEF={ 500}
40021 "START Gain PSI 1-255" {0, 1, 255} DEF={ 200}
40022 "START Reset Rate 0.01-9.99s" {0, 1, 999} DEF={ 20}
40023 "Act. Kick Counts " {0, 0, 1000} DEF={ 500}
** RPM Control ** {type,Min,Max } {Default}
40024 "ACCEL Max Accel Rate RPM/sec" {0, 50, 9999} DEF={ 2000}
40025 "ACCEL Acc Err Limit RPM/sec" {0, 50,16383} DEF={ 2000}
40026 "ACCEL Accel Limit RPM RPM " {0, 10, 500} DEF={ 30}
40027 "ACCEL Gain Accel 1-255" {0, 1, 255} DEF={ 180}
40028 "ACCEL Reset Rate 0.01-9.99s" {0, 1, 999} DEF={ 40}
40029 "ACCEL Brake Percent 1-100%" {0, 1, 99} DEF={ 15}
** Engine Config ** {type,Min,Max } {Default}
40030 "RPM Minimum (also warmup) " {1,00000, 3000} DEF={ 200}
40031 "RPM Maximum " {1,00000, 3000} DEF={ 300}
40032 "Crank Speed (begin purge) " {0,00000, 3000} DEF={ 50}
40033 "Overspeed shutdown 0-1000" {0,00000, 3000} DEF={ 330}
40034 "Gearteeth " {1, 60, 1000} DEF={ 360}
40035 "KReloadDivider:KToothDly " {65, 257,65535} DEF={ 2815}
40036 "KTimeDly " {65, 1, 255} DEF={ 3}
40037 "RPM_LB:ACC_LB " {65, 257, 7681} DEF={ 6401}
40038 "Purge Time 0-999s" {0,00000, 999} DEF={ 5}

```

```

40039 "Warmup Time 0-999s" {0,00000, 999} DEF={ 30}
40040 "Shutdown Lo FSP PSIG*100" {0,00000,12000} DEF={ 6000}
40041 "Shutdown Hi FMP PSIG*100" {0,00000,12000} DEF={ 4000}
40042 "FSP ready limit PSIG*100" {0,00000,12000} DEF={ 200}
40043 "FMP ready limit PSIG*100" {0,00000,12000} DEF={ 200}
** Flow Config ** {type,Min,Max } {Default}
40044 "Flow Calibration " {0,00000,65535} DEF={ 4200} v2.0 range
40045 "DPOffset " {0,00000,65535} DEF={58200}
40046 "Shutdown Hi SCFM (power) " {0,00000,65535} DEF={60000}
40047 "Shutdown Hi SCFR (torque) " {0,00000,65535} DEF={60000} v2.0 scale
40048 "Shutdown limit SCFx 0-999sec" {0,00000, 999} DEF={ 300}
** Analog1 Config ** {type,Min,Max } {Default}
40049 "ANA1 30k register of interest " {0,00000,65535} DEF={30033} //SCFM
40050 "ANA1 30k register min value " {0,00000,65535} DEF={ 0}
40051 "ANA1 30k register max value " {0,00000,65535} DEF={ 500}
40052 "ANA1 min ma * 100 " {0, 300, 2500} DEF={ 400}
40053 "ANA1 max ma * 100 " {0, 300, 2500} DEF={ 2000}
** Analog2 Config ** {type,Min,Max } {Default}
40054 "ANA2 30k register of interest " {0,00000,65535} DEF={30012} //RPM
40055 "ANA2 30k register min value " {0,00000,65535} DEF={00000}
40056 "ANA2 30k register max value " {0,00000,65535} DEF={ 400}
40057 "ANA2 min ma * 100 " {0, 300, 2500} DEF={ 400}
40058 "ANA2 max ma * 100 " {0, 300, 2500} DEF={ 2000}
** Sensor Config ** {type,Min,Max } {Default}
40059 "FuelSupplyPres Sensor Span " {0, 3000,27300} DEF={26000} v2.0 range
40060 "FuelSupplyPres Sensor Zero " {128,-1300,1300} DEF={00000}
40061 "FuelManifoldPres Sensor Span " {0, 3000,27300} DEF={26000} v2.0 range
40062 "FuelManifoldPres Sensor Zero " {128,-1300,1300} DEF={00000}
40063 "FuelControlPress Sensor Span " {0, 3000,27300} DEF={26000} v2.0 range
40064 "FuelControlPress Sensor Zero " {128,-1300,1300} DEF={00000}
40065 "AirManifoldPress Sensor Span " {0, 0, 65535} DEF={00000}
40066 "AirManifoldPress Sensor Zero " {128,-32768,32767}DEF={00000}
40067 "AUX2 Sensor Span " {0, 0, 65535} DEF={00000}
40068 "AUX2 Sensor Zero " {128,-32768,32767}DEF={00000}
** H/W Config ** {type,Min,Max } {Default}
40069 "Uart #1 baud:node " {64, 1, 2047} DEF={ 1281} //9600baud:1node
40070 "Starve % " {0, 1, 150} DEF={ 95} v2.0 range
40071 "Act. Pressure Max (factory) " {0, 1000, 2200} DEF={ 2000}
40072 "Atmospheric Constant psi*100 " {0, 700, 1600} DEF={ 1400} v2.0 range
** new registers for start mode ** {type,Min,Max } {Default}
40073 "Start Abort FMP PSIG*100" {0, 0,15000} DEF={ 2500} v2.0 new
40074 "Start Type 0=fmp,1=scfr,2=scfm" {0, 0, 1} DEF={ 0} v2.0 new
40075 "Start base SCFR*10000 " {0, 0,65000} DEF={01500} v2.0 new
** new registers for SCFR start mode** {type,Min,Max } {Default}
40076 "CL SCFR Max Rate SCFR*10000/s" {0, 5,16383} DEF={01000} v2.0 new
40077 "CL SCFR Err Lim SCFR*10000/s" {0, 5,16383} DEF={01000} v2.0 new
40078 "CL Rate Lim SCFR SCFR*10000" {0, 5,16383} DEF={00500} v2.0 new
40079 "CL SCFR Gain 1-255" {0, 1, 255} DEF={ 200} v2.0 new
40080 "CL SCFR Reset Rate 0.01-9.99s" {0, 1, 999} DEF={ 20} v2.0 new
** new registers for analog outs ** {type,Min,Max } {Default}
40081 "DAC0 Dampener 0-254 0=NoFilter" {0, 0, 254} DEF={ 1} v2.0 new
40082 "DAC1 Dampener 0-254 0=NoFilter" {0, 0, 254} DEF={ 1} v2.0 new

```

GOV10 Enumeration definitions for the "Stop At" and "Stop Cause" bytes

Enumeration Strings for Decode

REG30009 GOV_STATE_NOW

```
0,    "READY"
1,    "NOT READY"
2,    "ROTATE"
3,    "PURGE"
4,    "PURGED"
5,    "SHUT DOWN"
6,    "WARMUP"
7,    "RUN"
8,    "START"
9,    "FAULT"
10,   "ACT. TEST"
Else, "?????"      'for case of some undefined input data'
```

Enumeration Strings for Decode

REG30049 GOV_STOP_CAUSE

```
0,    "POWERUP"      'meaning no stop occurred since power up.'
1,    "Stop = OverSpeed"
2,    "Stop = SawFSP"
3,    "Stop = SawFMP"
4,    "Stop = LoRPM"
5,    "Stop = FSPWaitTime"
6,    "Stop = StartTime"
7,    "Stop = HiFMP"
8,    "Stop = LoFSP"
9,    "Stop = HiSCFM"
10,   "Stop = AbortFMP"
11,   "Stop = FaultFMP"
Else, "Stop = ??????"      'for case of some undefined input data'
```

Enumeration Strings for Decode

REG30050 GOV_STOP_STATE

```
0,    " @ READY"
1,    " @ NOT READY"
2,    " @ ROTATE"
3,    " @ PURGE"
4,    " @ PURGED"
5,    " @ SHUT DOWN"
6,    " @ WARMUP"
7,    " @ RUN"
8,    " @ START"
9,    " @ FAULT"
ELSE, " @ ??????"      'for case of some undefined input data'
```

GOV10/50 SETUP & CONFIGURATION WORKSHEET

Customer: _____ Station: _____
Engine Model: _____ Unit No. _____
GOV P/N: _____ GOV S/N: _____ Date Installed: _____

Setup

LocalRPM = _____ (275) [MinRPM-MaxRPM]
Remote RPM = _____ (OFF) [OFF, ON]
RPM DAMP = _____ (240) [0-255]

Start Config

StartRPM = _____ (150) [1-MinRPM]
StartFMP = _____ (5) [0-50]
RampFMP = _____ (0) [0-2]
AMPbias = _____ (0) [0-10]
LimitFMP = _____ (15) [0-50]
AbortFMP = _____ (20) [0-50]
AbortSEC = _____ (20) [0-999]
FSPabortsec= _____ (20) [0-999]

Start Control

RateLimPSI = _____ (5) [.50-99]
MaxPSIRate = _____ (5) [.05-99]
PSIerrLim = _____ (10) [.05-99]
GainPSI = _____ (175) [1-255]
RstRatePSI = _____ (.20) [.01-99]
ActKick = _____ (450) [0-1000]

RPM Control

AccLimRPM = _____ (40) [10-500]
MaxAccRate = _____ (40) [.5-99]
AccErrLim = _____ (20) [.5-163]
GainAccel = _____ (100) [1-255]
RstRateAcc = _____ (.50) [.01-99]
Brake % = _____ (15) [1-99]

Hardware Config

RTU Node = _____ (1) [1-250]
RTU Baud = _____ (9600) [300, 600, 1200, 4800, 9600, 19.2k, 38.4k]
Starve % = _____ (95) [1-150]
ActPmax = _____ (20) [10-22]
BaroDflt = _____ (14.00) [13.5-15.5]

AnalogOut#1 CFG

Register = _____ (30033) [0, 65535, 30001-30128, 31001-31128] (default=scfm)
Reg.Min = _____ (0) [0-65535, +/-32767]
Reg.Max = _____ (500) [0-65535, +/-32767]
mA.Min = _____ (4.00) [3.00-25.00]
mA.Max = _____ (20.00) [3.00-25.00]
mA.Damp = _____ (1) [0-254]

AnalogOut#2 CFG

Register = _____ (30012) [0, 65535, 30001-30128, 31001-31128] (default=rpm)
Reg.Min = _____ (0) [0-65535, +/-32767]
Reg.Max = _____ (400) [0-65535, +/-32767]
mA.Min = _____ (4.00) [3.00-25.00]
mA.Max = _____ (20.00) [3.00-25.00]
mA.Damp = _____ (1) [0-254]

Engine Config

MinRPM = _____ (200) [1-3000]
MaxRPM = _____ (300) [1-3000]
OverspdRPM= _____ (330) [1-3000]
CrankRPM = _____ (10) [1-3000]
GearTeeth = _____ (360) [60-999]
PurgeSEC = _____ (5) [0-999]
WarmupSEC = _____ (30) [0-999]
FSPshutdn = _____ (60) [0-120]
FMPshutdn = _____ (40) [0-120]
FSPready = _____ (2) [0-120]
FMPready = _____ (2) [0-120]
StartType = _____ (FMP) [FMP, SCFR]

Flow Config

SCFMscale = _____ (~5250) [0-65535]
Dpzero = _____ (~58500) [0-65535]
SCFM SD = _____ (60000) [1-65535]
SCFR SD = _____ (6.0000) [0.1-6.5535]
SCFxSDsec = _____ (999) [0-999]

Sensor CFG

FSP.Span = _____ (~260.) [247-273]
FSP.Zero = _____ (~0.00) [+/-13]
FMP.Span = _____ (~260.) [247-273]
FMP.Zero = _____ (~0.00) [+/-13]
FCP.Span = _____ (~260.) [247-273]
FCP.Zero = _____ (~0.00) [+/-13]
AMP.Span = _____ (~0.00) [0-655]
AMP.Zero = _____ (~0.00) [+/-327]

DRAWINGS:

- 809007 GOV10 GAS METERING VALVE, 2" 4-BOLT FLANGE
- 809008 GOV10 GAS METERING VALVE, 2" 8-BOLT FLANGE
- 809009 GOV10 INTERNAL FLOW ARRANGEMENTS
- 809010 GOV50 GOVERNOR, 2" 4-BOLT ASSEMBLY
- 809011 GOV10 GOVERNOR FILTER CONFIGURATION
- 809012 STANDARD INSTALLATION, WITH EXT. FILTER AND VENTING
- 809013 GOV10 FUEL CONTROL
- 809014 WIRING DETAIL FOR EXTERNAL WIRING
- 809015 PICKUP MOUNTING DETAIL, GOVERNOR SYSTEM
- 809016 DISPLAY MODULE, GOVERNOR
- 809017 DISPLAY MODULE, GOVERNOR WIRING DIAGRAM
- 809018 NEMA 12 ENCLOSURE
- 809019 SHIELDED HARNESS CONDUIT LENGTH ADJUSTMENT
- 809020 GOV10/50 SYSTEM WIRING DIAGRAM

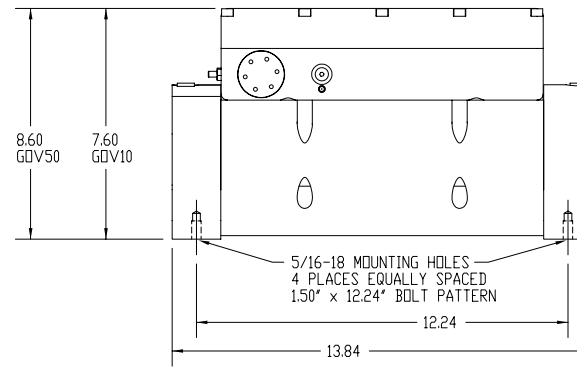
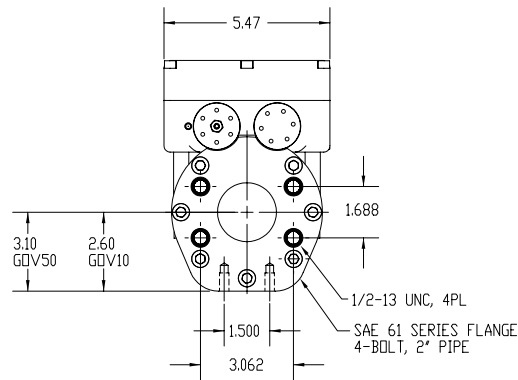
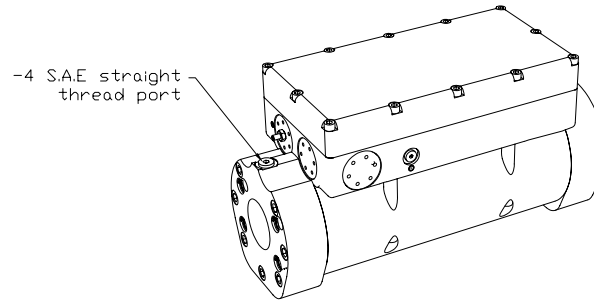

NOTE:

ENGINE FUEL GAS MUST BE CLEAN AND DRY FOR PROPER OPERATION OF THE GOV SYSTEM.

REVISIONS				TOLERANCES (EXCEPT AS NOTED)	ALTRONIC INC.				
NO.	DATE	BY	DESCRIPTION	DECIMAL .XXX - ±.005 .XX - ±.010	TITLE GOV10/GOV50 GAS METERING VALVE 2" 4-BOLT FLANGE				
1	5-20-05	WTP	ECN 050000	FRACTIONAL	DRAWN BY	WTP	SCALE	NONE	DRAWING NUMBER 809 007
2				MATERIAL	CHECKED BY		DATE	7-18-03	
3					APPROVED BY				
4									
5									

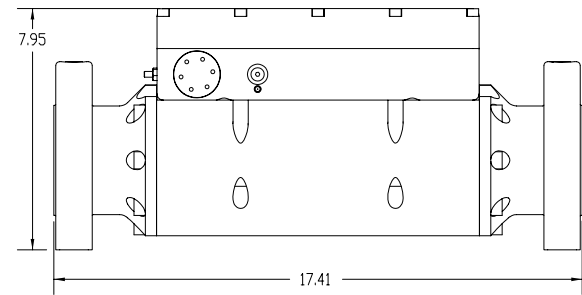
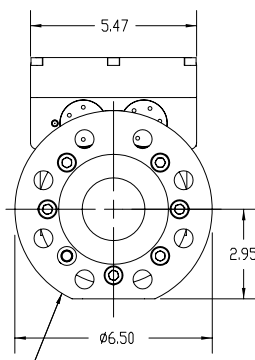
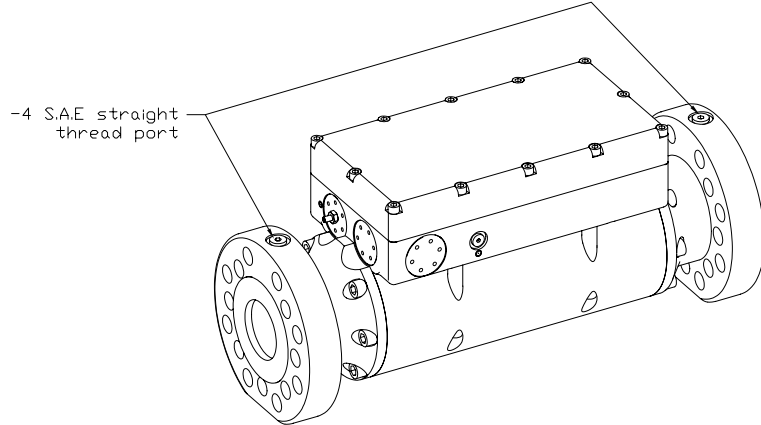

NOTE:
ENGINE FUEL GAS MUST BE CLEAN AND DRY
FOR PROPER OPERATION OF THE GOV SYSTEM.

CLASS 300 PIPE FLANGE
8-BOLT, 2" PIPE, 6.50" O.D.
5.00" BOLT CIRCLE

REVISIONS				TOLERANCES (EXCEPT AS NOTED)		ALTRONIC INC.		
NO.	DATE	BY	DESCRIPTION	DECIMAL	FRACTIONAL	TITLE		DRAWING NUMBER
1	5-20-05	WTP	ECN 050000	.XXX - ±.005		GOV10 GAS METERING VALVE		
2				.XX - ±.010		2" 8-BOLT FLANGE		
3						DRAWN BY	WTP	SCALE NONE
4						CHECKED BY		DATE 7-18-03
5						APPROVED BY		809 008

809 008

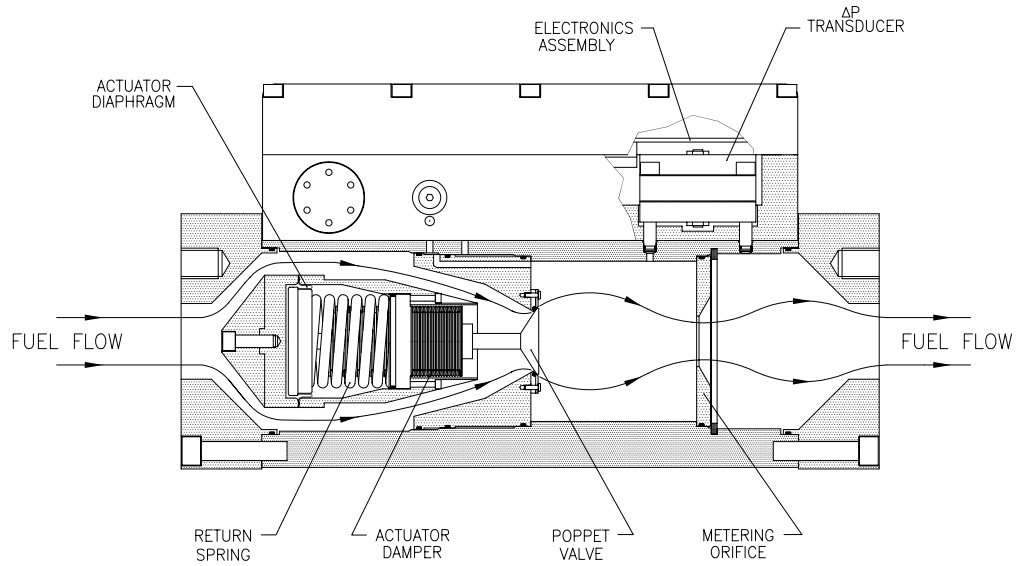

REVISIONS				TOLERANCES (EXCEPT AS NOTED)	ALTRONIC INC.				
NO.	DATE	BY	DESCRIPTION	DECIMAL .XXX - ±.005 .XX - ±.010	TITLE GOV INTERNAL FLOW ARRANGEMENT				
1				FRACTIONAL	DRAWN BY	WTP	SCALE	NONE	DRAWING NUMBER
2				MATERIAL	CHECKED BY		DATE	7-29-03	809 009
3					APPROVED BY				
4									
5									

600 608

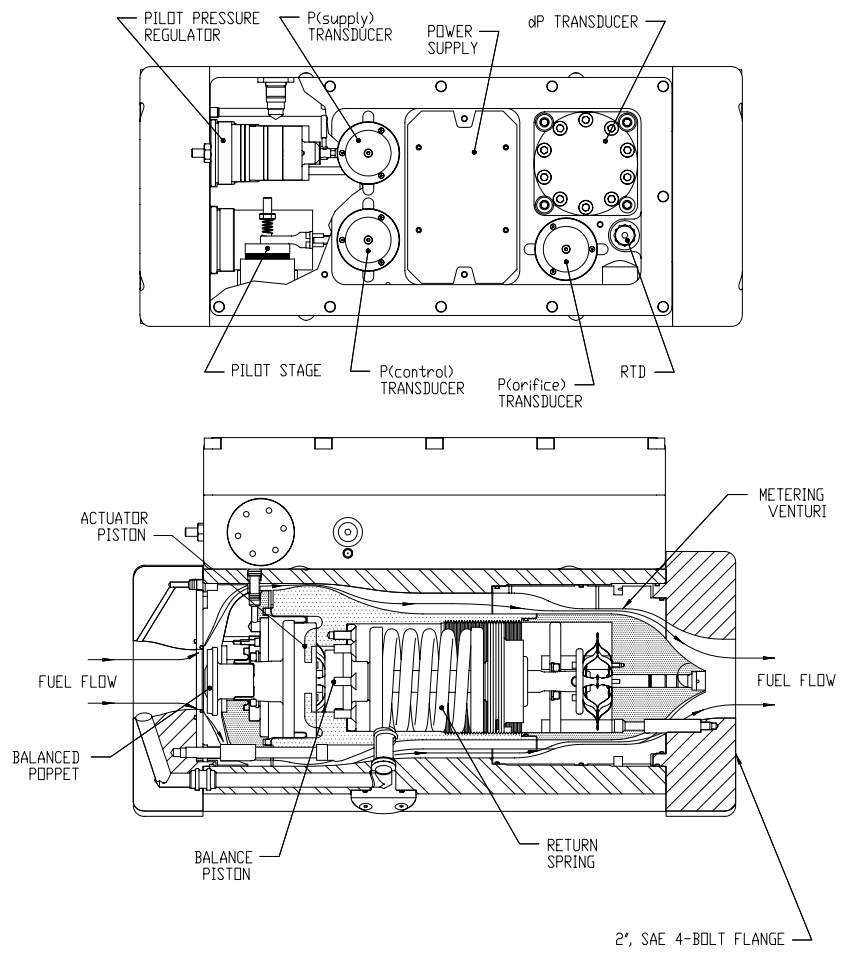

REVISIONS			
NO.	DATE	BY	DESCRIPTION
1	5-20-05	WTP	ECN 050000
2			
3			
4			
5			

TOLERANCES (EXCEPT AS NOTED)		ALTRONIC INC.	
DECIMAL .XXX - ±.005 .XX - ±.010	TITLE GOV50 GOVERNOR 2" 4-BOLT FLANGE, ASSEMBLY		
FRACTIONAL	DRAWN BY WTP	SCALE NONE	DRAWING NUMBER
MATERIAL	CHECKED BY	DATE 7-18-03	809 010
	APPROVED BY		

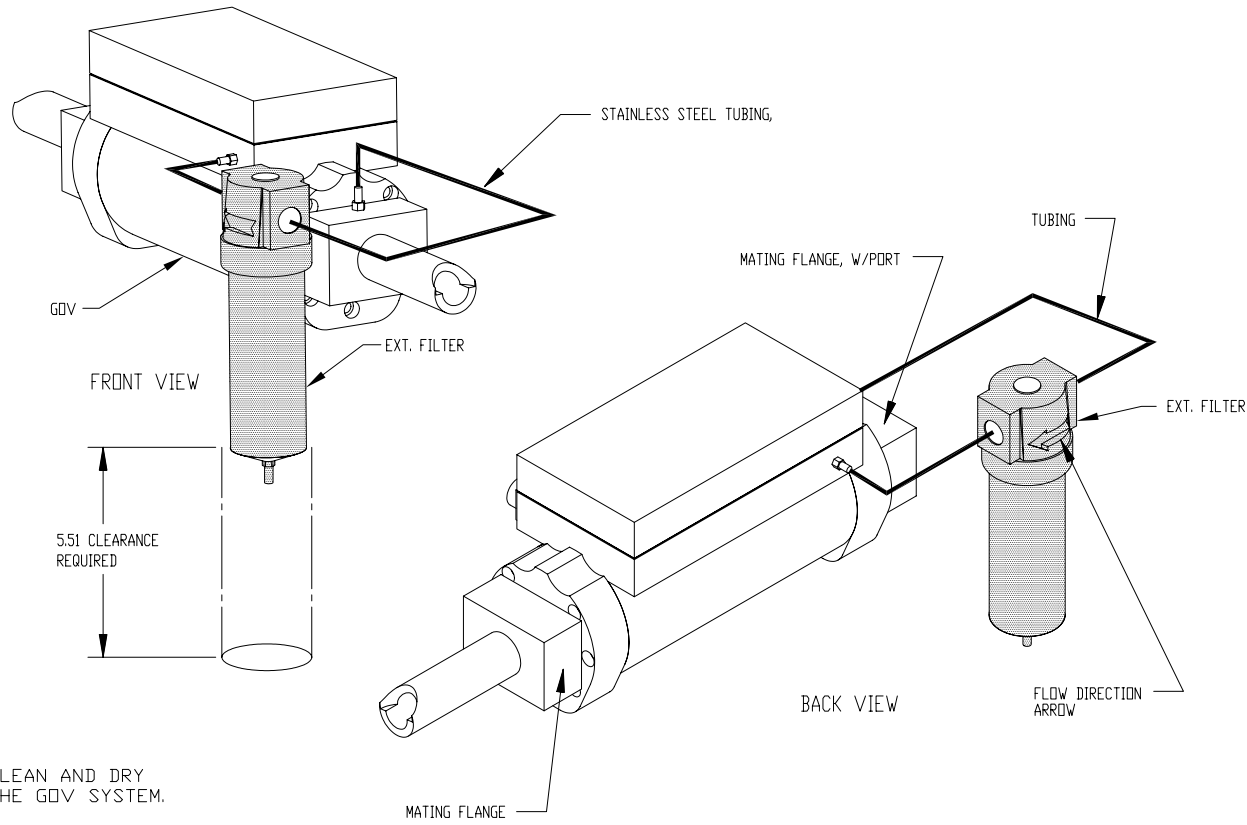

NOTE:
ENGINE FUEL GAS MUST BE CLEAN AND DRY
FOR PROPER OPERATION OF THE GOV SYSTEM.

REVISIONS				TOLERANCES (EXCEPT AS NOTED)	ALTRONIC INC.			
NO.	DATE	BY	DESCRIPTION	DECIMAL .XXX - ±.005 .XX - ±.010	TITLE GOV GOVERNOR EXTERNAL FILTER CONFIGURATION			
1	5-20-05	WTP	ECN 050000	FRACTIONAL	DRAWN BY	WTP	SCALE NONE	DRAWING NUMBER
2				MATERIAL	CHECKED BY	DATE	7-30-03	809 011
3					APPROVED BY			
4								
5								

809 011

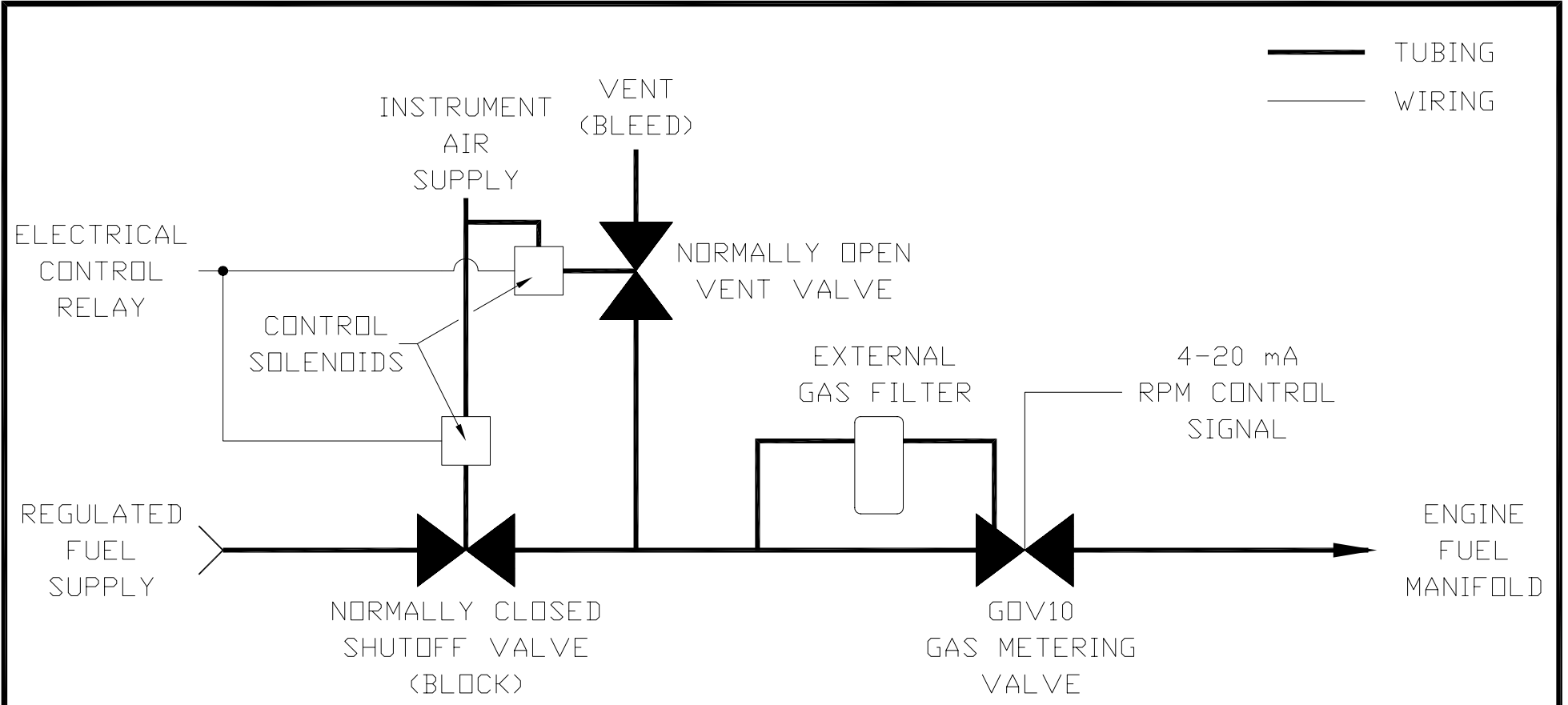

NOTE:
ENGINE FUEL GAS MUST BE CLEAN AND DRY
FOR PROPER OPERATION OF THE GOV SYSTEM.

REVISIONS				TOLERANCES (EXCEPT AS NOTED)	ALTRONIC INC.			
NO.	DATE	BY	DESCRIPTION	DECIMAL .XXX - ±.005 .XX - ±.010	TITLE STANDARD INSTALLATION, WITH EXT. FILTER AND VENTING			
1	5-20-05	WTP	ECN 050000	FRACTIONAL	DRAWN BY	SCALE	NONE	DRAWING NUMBER
2				MATERIAL	CHECKED BY	DATE	7-29-03	809 012
3					APPROVED BY			
4								
5								

809 012

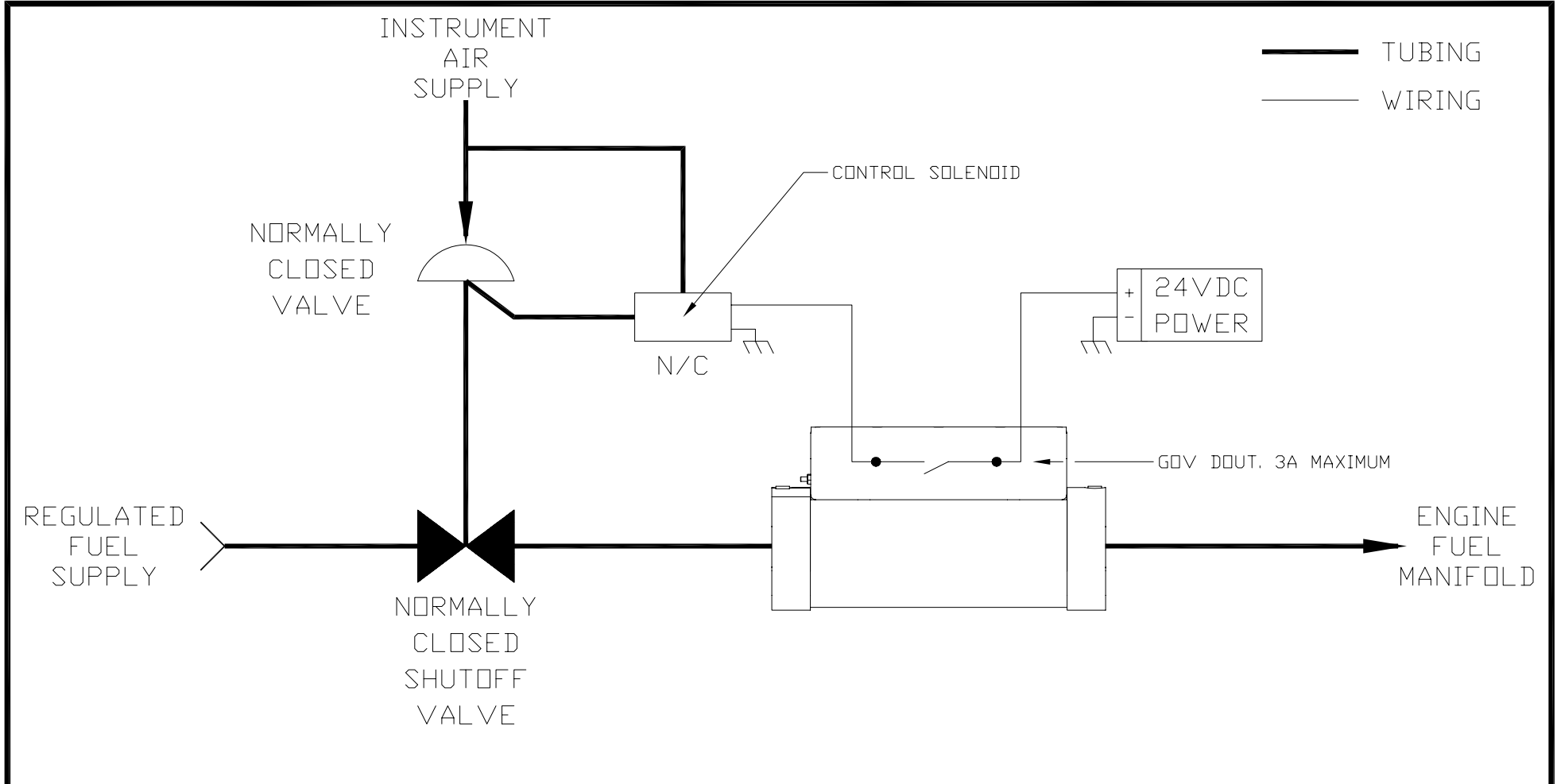

809 013

REVISIONS				TOLERANCES (EXCEPT AS NOTED)	ALTRONIC INC.		
NO.	DATE	BY	DESCRIPTION	DECIMAL .XXX - ±.005 .XX - ±.010	TITLE GOV FUEL CONTROL		
1				FRACTIONAL	DRAWN BY: GET/WTP	SCALE: NONE	DRAWING NUMBER
2				MATERIAL	CHECKED BY	DATE: 7-29-03	809 013
3					APPROVED BY		
4							
5							

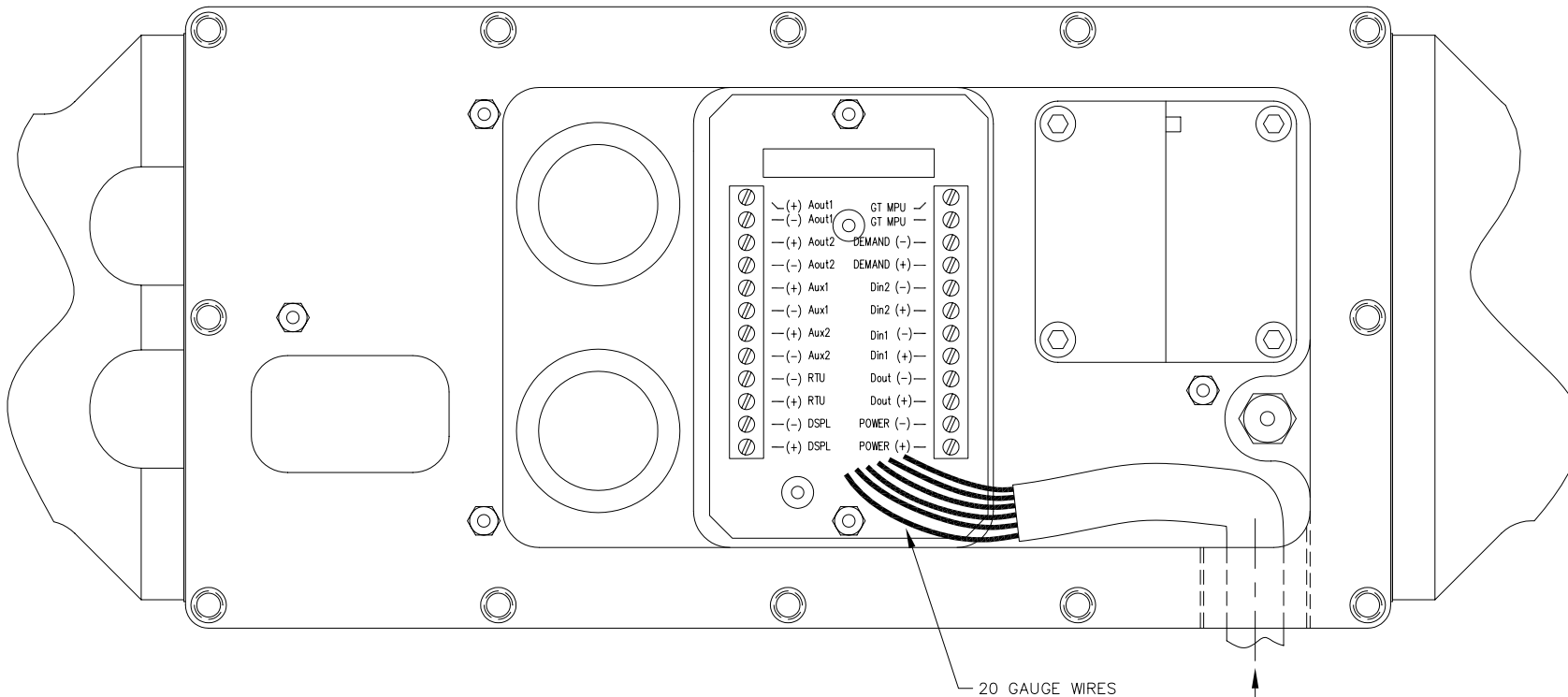

NOTES:

1. REMOVE LOGIC PCB AND TERMINAL LABEL FOR ACCESS TO TERMINAL BOARD.
2. USE WIRING CHART FOR GOV UNIT TO MATCH HARNESS WIRES WITH TERMINAL LOCATIONS.
3. REPLACE TERMINAL LABEL AND LOGIC PCB WHEN COMPLETED.

CUSTOMER SUPPLIED
FIELD WIRING
OR
893003 ADAPTER

REVISIONS				TOLERANCES (EXCEPT AS NOTED)	ALTRONIC INC.				
NO.	DATE	BY	DESCRIPTION	DECIMAL .XXX - ±.005 .XX - ±.010	TITLE		DRAWING NUMBER		
1				FRACTIONAL	DRAWN BY	WTP		SCALE	NONE
2				MATERIAL	CHECKED BY	DATE	7-29-03		
3					APPROVED BY				
4									
5									

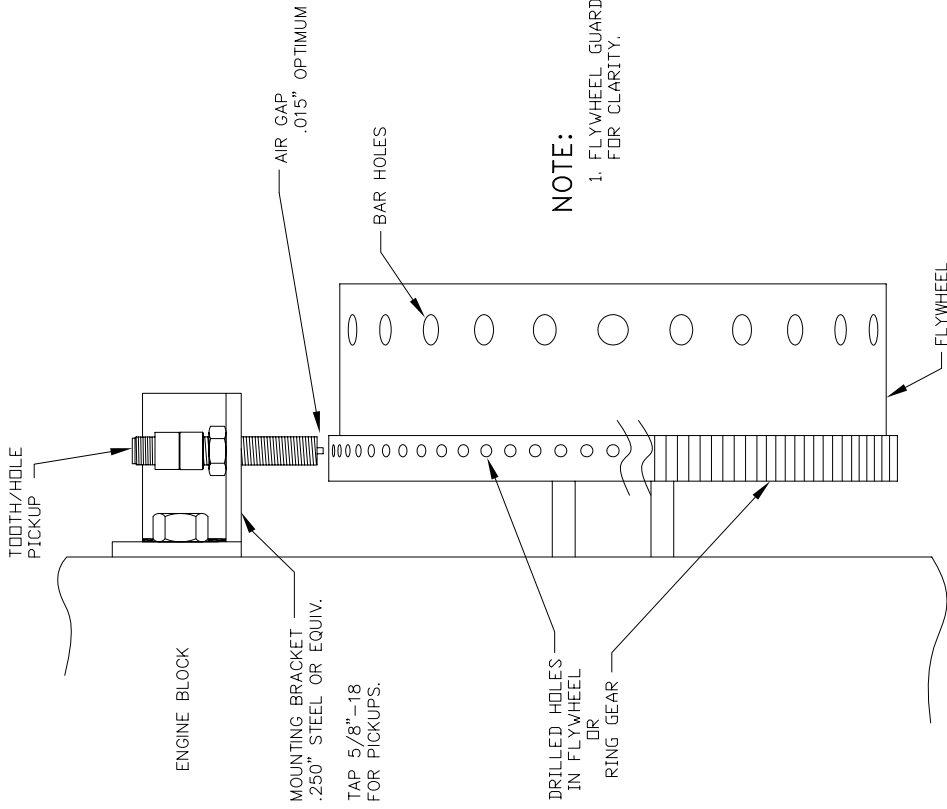

NOTE:
1. FLYWHEEL GUARD NOT SHOWN FOR CLARITY.

NOTE:
VISUAL PROPORTION OF THIS ILLUSTRATION WILL CHANGE WITH VARIATIONS IN GEAR AND FLYWHEEL SIZE AND RELATIONSHIP.

REVISIONS		TOLERANCES (EXCEPT AS NOTED)	
NO.	DATE	BY	DESCRIPTION
1			
2			
3			
4			
5			

DECIMAL .XX - +.005 .XX - -.010	TITLE PICKUP MOUNTING DETAIL, GOVERNOR SYSTEM	
FRACTIONAL	DRAWN BY WTP	SCALE NONE
MATERIAL	CHECKED BY	DATE 7-18-03
	APPROVED BY	DRAWING NUMBER 809 015

ALTRONIC INC.

SPECIFICATIONS:

POWER: 24 VDC AT 150 mA NOMINAL, 32 VDC AT 250 mA MAX.
 ENCLOSURE: WEATHERPROOF, POWDER COATED ALUMINUM
 FIELD CONNECTIONS: PLUG-IN TERMINAL STRIPS ON BACK
 CONTROL INPUTS: RS485 SERIAL COMMUNICATIONS PORT

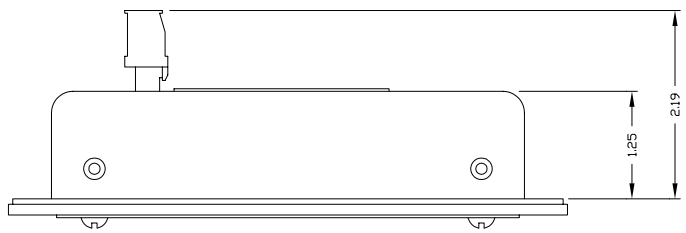
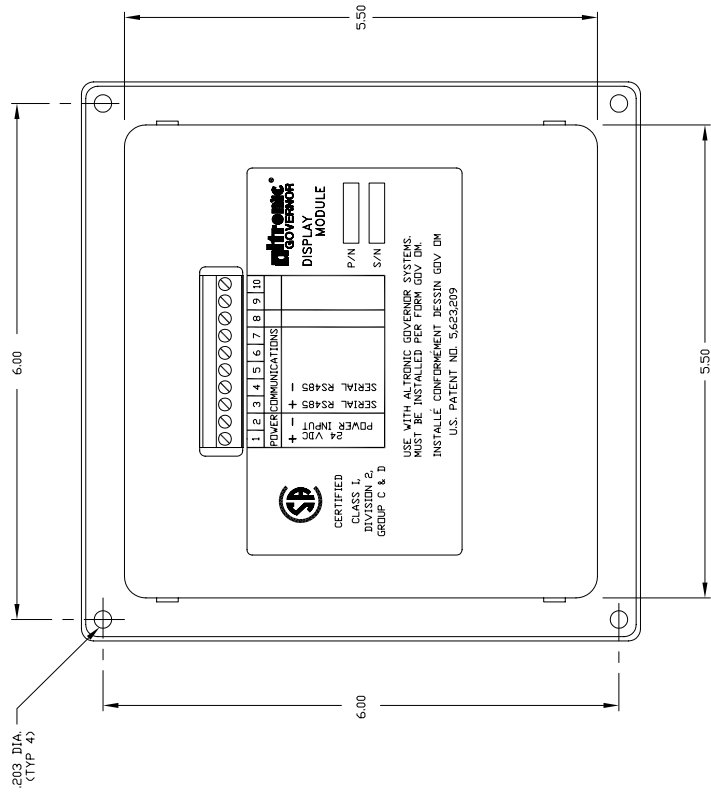
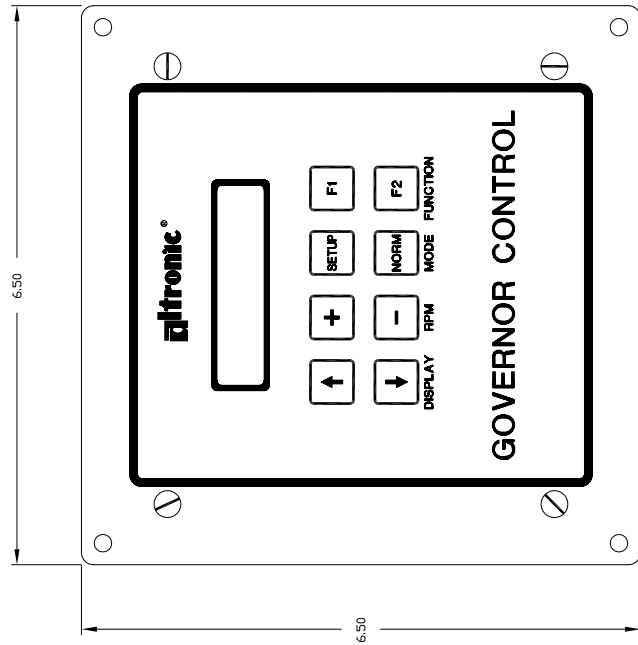

REVISIONS		TOLERANCES UNLESS NOTED	
NO.	DATE	BY	DESCRIPTION
1			
2			DECIMAL PLACES .XXX - 2.00
3			FRACTIONAL
4			MATERIAL
5			

ALTRONIC INC.			
TITLE DISPLAY MODULE, GOVERNOR			
DRAWN BY	WTP	SCALE	FULL
CHECKED BY		DATE	7-18-03
APPROVED BY			
			DRAWING NUMBER
			809 016

TERMINAL STRIP
IN GOVERNOR

POWER + -
+ -
+ -
+ -

NOTE 3

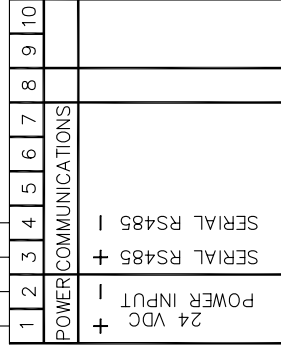

DISPLAY MODULE

NOTE:

1. INPUT POWER REQUIREMENT FOR DISPLAY MODULE IS 24 VDC 150 mA NOMINAL.
2. POWER GROUNDS FOR THE DISPLAY MODULE AND THE GOVERNOR SYSTEM MUST BE AT THE SAME GROUND POTENTIAL FOR PROPER OPERATION OF THE RS-485 COMMUNICATIONS.
3. USE 4-CONDUCTOR SHIELDED CABLE (RECOMMEND ALTRONIC 503194) FOR POWER AND RS-485 CONNECTIONS. CONNECT SHIELD IN THE J-BOX.

REVISIONS

NO.	DATE	BY	DESCRIPTION
1			
2			
3			
4			
5			

TOLERANCES (EXCEPT AS NOTED)	
DECIMAL	.XXX - ±.005 .XX - ±.010
FRACTIONAL	
MATERIAL	

ALTRONIC INC.			
TITLE		WIRING DIAGRAM, DISPLAY MODULE, GOVERNOR	
DRAWN BY	WTP	SCALE	NONE
CHECKED BY		DATE	10-17-03
APPROVED BY		DRAWING NUMBER 809 017	

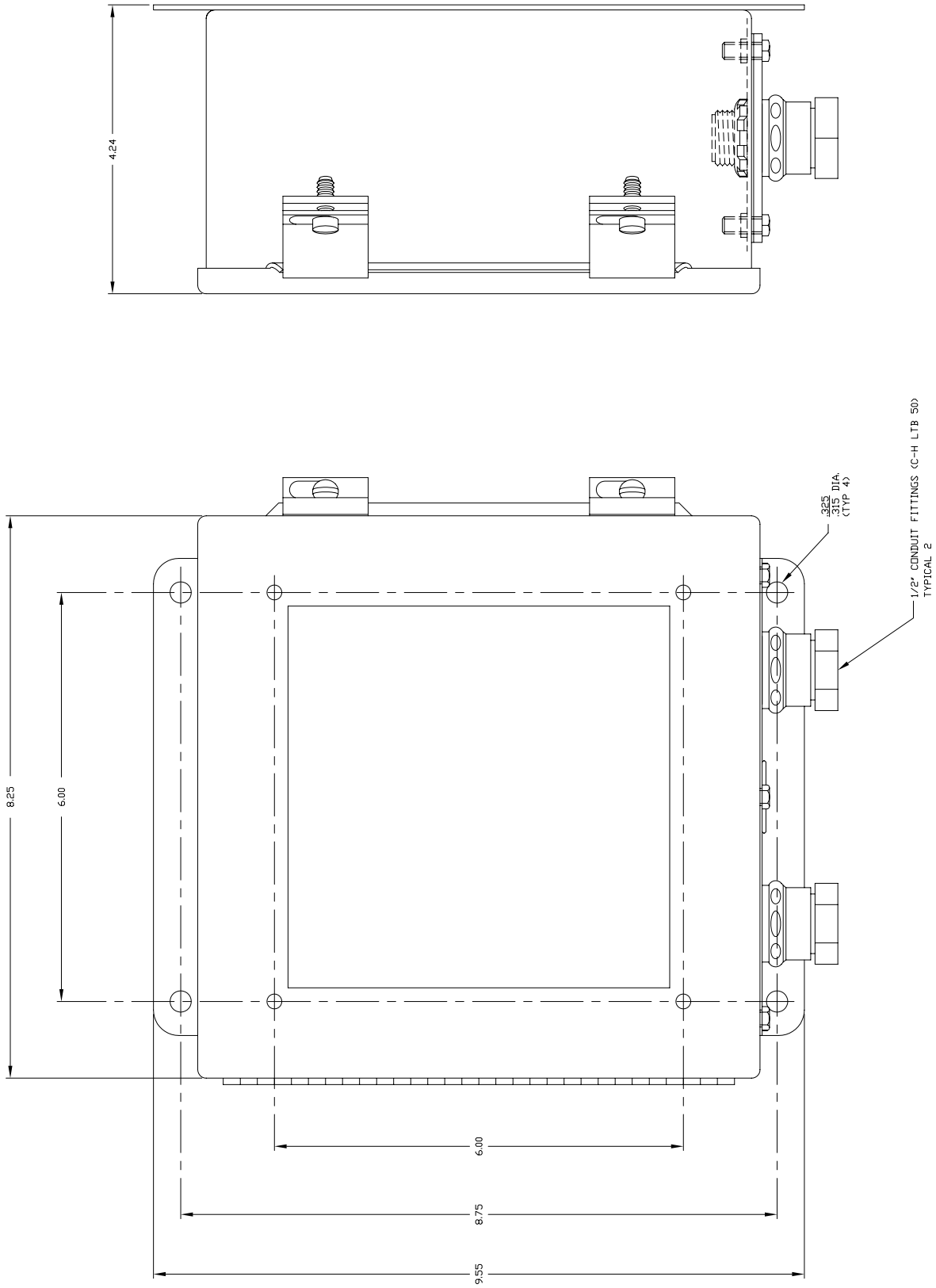

REVISIONS		TOLERANCES UNLESS AS NOTED	
NO.	DATE	BY	DESCRIPTION
1			
2			
3			
4			
5			

DECIMAL	±.005	
FRACTIONAL	XXX - ±.010	
MATERIAL		

ALTRONIC INC.			
TITLE NEMA 12 ENCLOSURE			
DRAWN BY	VTP	SCALE	FULL
CHECKED BY		DATE	7-18-03
APPROVED BY			

TO SHORTEN HARNESS

1. LOOSEN AND DISENGAGE NUT (2) AND REMOVE CONDUIT (1) COMPLETELY FROM CONNECTOR AND HARNESS ASSEMBLY (3).
2. REMOVE ITEMS (5), (4), AND (2) IN THAT ORDER FROM CONDUIT (1). NOTE THREADS ON (5).
3. CUT CONDUIT TO LENGTH WITH HACKSAW AND DRESS WITH FILE TO INSURE A CLEAN, SQUARE END. REMOVE FILINGS FROM INSIDE CONDUIT.
4. REINSTALL ITEMS (2), (4), AND (5) IN THAT ORDER.
5. INSTALL REASSEMBLED CONDUIT INTO (3) AND TIGHTEN (2).

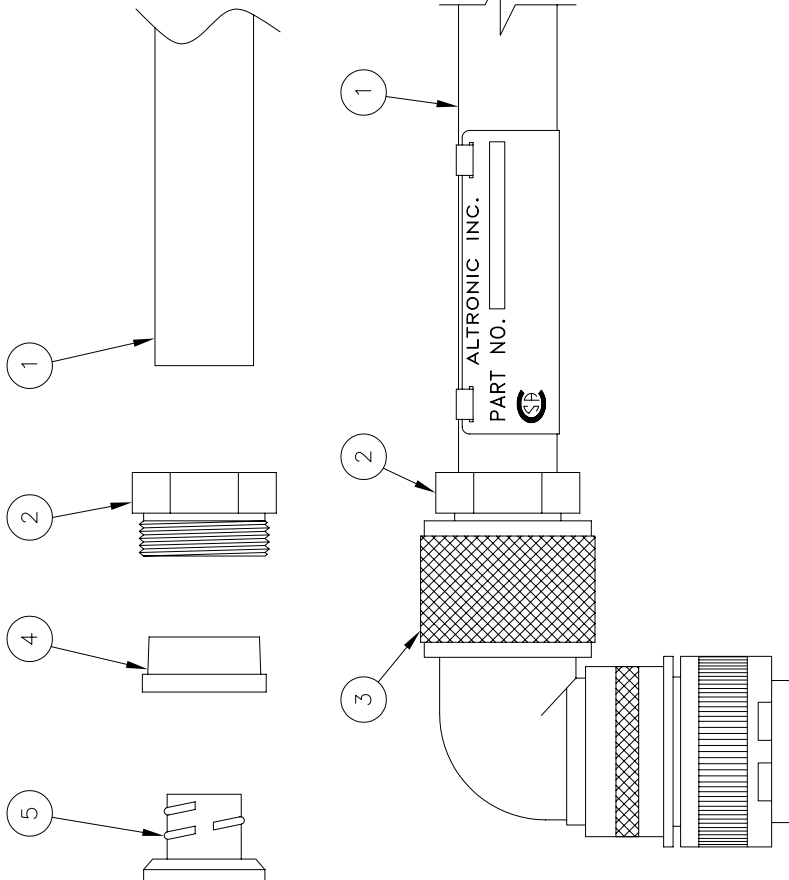

REVISIONS

NO.	DATE	BY	DESCRIPTION
1			
2			
3			
4			
5			

TOLERANCES (EXCEPT AS NOTED)	
DECIMAL	.XX - ±.005
FRACTIONAL	.XX - ±.010
MATERIAL	

ALTRONIC INC.			
TITLE		SHIELDED HARNESS	
CONDUIT LENGTH ADJUSTMENT		PART NUMBER	
DRAWN BY	WTP	SCALE	NONE
CHECKED BY		DATE	7-18-03
APPROVED BY			809 019

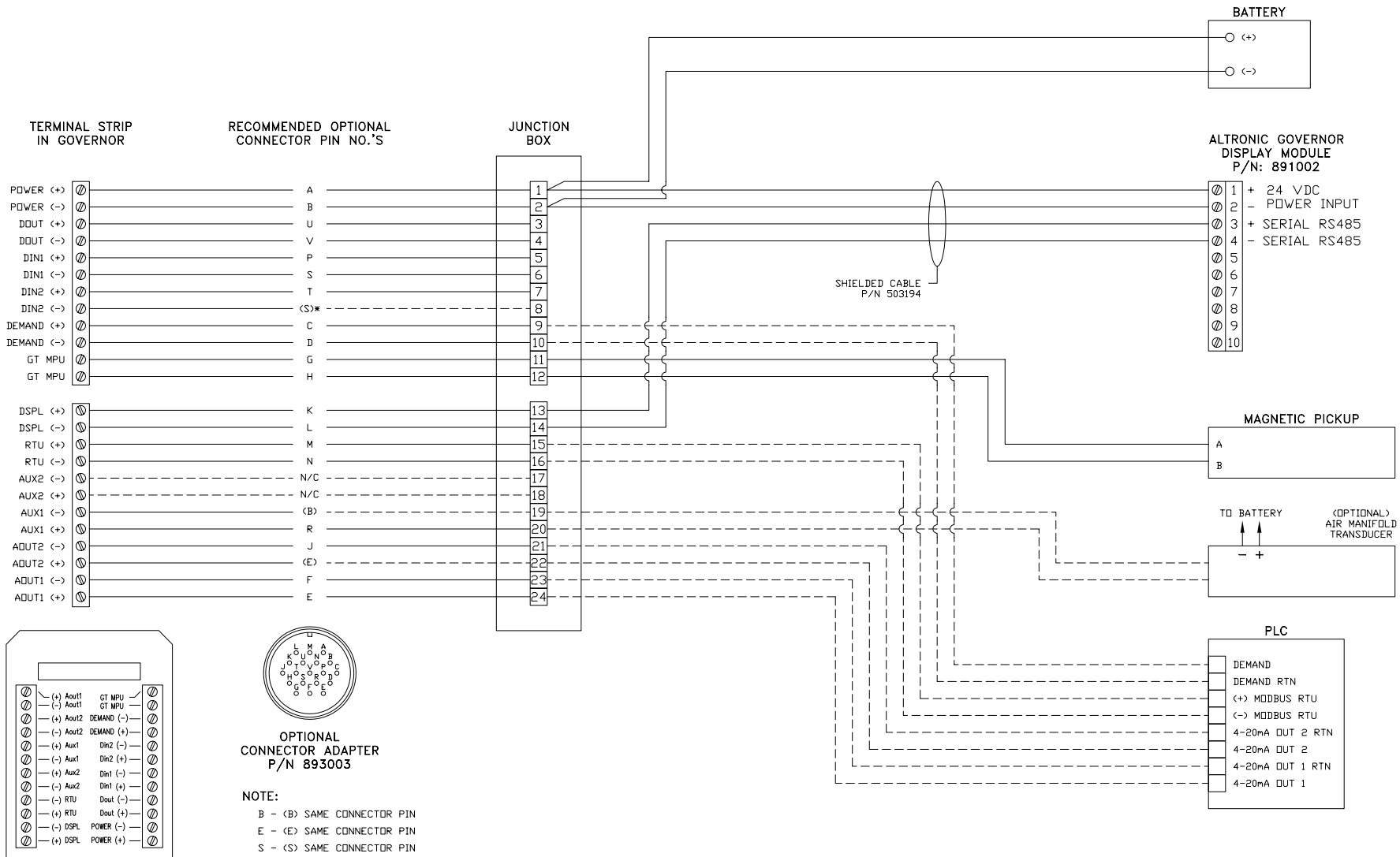

NOTE:
CONDUIT SEALS AS REQUIRED.

809 020

REVISIONS				TOLERANCES (EXCEPT AS NOTED)	ALTRONIC INC.				
NO.	DATE	BY	DESCRIPTION		TITLE				
1				DECIMAL .XXX - ±.005	GDV10/50 SYSTEM WIRING DIAGRAM				
2				FRACTIONAL .XX - ±.010					
3					DRAWN BY	W/TP	SCALE	NONE	DRAWING NUMBER
4					CHECKED BY	DATE	3-17-04		809 020
5					APPROVED BY				