

WARNING: DEVIATION FROM THESE INSTALLATION INSTRUCTIONS MAY LEAD TO IMPROPER ENGINE OPERATION WHICH COULD CAUSE PERSONAL INJURY TO OPERATORS OR OTHER NEARBY PERSONNEL.

1.0 OVERVIEW

- 1.1 This manual provides installation instructions and maintenance information for the Altronic Gas Control Valve, models 690220-1 (2" NPT), 690225-1 (2.5" NPT) and 690230-1 (3" NPT). It is recommended that the user read this manual in its entirety before commencing operations.

It is not our intention to instruct others on how to design control systems, nor can we assume responsibility for their safe operation. This advice is intended to help the end user install the Altronic Gas Control Valve in such a manner to reduce the risk of accident to personnel or to equipment.

Do **NOT** attempt to operate, maintain, or repair the fuel control valve until the contents of this document have been read and are thoroughly understood.

- 1.2 The Altronic Gas Control Valves are normally used with natural gas. Natural gas and air, when combined together, become very combustible and when contained within an enclosure, such as a gas engine or its exhaust system, can explode in a violent manner when ignited. It is necessary to always use extreme caution when working with any fuel system. The control systems used with gas engines or other similar machines should always be designed to be "fail-safe".
- 1.3 The Gas Control Valve is **NOT** a shutoff valve. Shutoff valves must be used in addition to the control valve. The fuel system should be designed in such a way that:
- no failure of a single component will cause the fuel system to admit fuel to the engine when the engine has been shutdown, and
 - no single failure can result in grossly over-fueling the engine when attempting to start.

WARNING: Failure to follow the above rules may lead to serious damage to equipment or to personnel.

- 1.4 Maximum gas working pressure is **50 psig**. Gas pressure at the valve must **NOT** exceed this rating at any time.

2.0 INSTALLATION

- 2.1 The Gas Control Valve should be inspected immediately after unpacking. Check for any damage that may have occurred during shipping. If there are any questions regarding the physical integrity of the valve, contact the distributor or Altronic, Inc.
NOTE: If possible, keep the original shipping container. If future transportation or storage of the valve is necessary, this container will provide the optimum protection.
- 2.2 The Gas Control Valve is designed to be installed on natural gas fired, reciprocating engines. It is a flow-control device that responds directly to the control output of the Altronic EPC-100 and EPC-150 series of Air Fuel Ratio controllers. Additionally, by the use of a special adaptor device, Altronic P/N 691156-1, the valve can be made to control based upon a 4 to 20 mA signal from a general purpose controlling device such as a PLC. In all cases the valve is installed between the fuel supply pressure regulator and the carburetor and is used to throttle the fuel available to the engine. When considering where to place the Gas Valve, choose a location away from any extreme sources of heat. Operating ambient temperature is -40°F to $+185^{\circ}\text{F}$ (-40°C to $+85^{\circ}\text{C}$). Do not expose the valve to temperatures higher than indicated here.

3.0 MOUNTING THE FUEL CONTROL VALVE

- 3.1 In order to control the air/fuel ratio, the electronically controlled valve is connected in series between the regulator and carburetor or mixer. The valve should be installed as close to the fuel inlet of each carburetor or mixer as possible. The distance from the valve to the carburetor inlet should not exceed 12 pipe diameters in length. The preferred mounting of the valve would be in the vertical position, with the Flow arrow pointing up or down. Horizontal mounting of the valve is acceptable as long as the valve is **NOT** installed with the control cable connector facing downward. This is necessary to avoid the collection of condensation in the electronics housing. See FIG. 1 for dimensional details.
- 3.2 If possible, gas connection piping should be of the same diameter as that currently in use. The control valve is available with 2, 2.5, and 3 inch NPT threads. The 2 inch NPT valve is part number 690220-1, the 2.5 inch NPT valve is part number 690225-1, and the 3 inch NPT valve is part number 690230-1. In some applications, the threaded connection to the valve body may require the use of thread adapters. If adapters are used, proper plumbing procedures must be followed.
- 3.3 Each control valve is connected to the EPC-100 or EPC-150 using the 693005-x cable. This cable has connectors on both ends and in unshielded installations these connectors are simply plugged into the valve and the EPC unit. If it is desired to enclose the cable in conduit, this can be easily accomplished by cutting the 693005 cable in half. The cables are color coded and must be reconnected inside a junction box with each wire color matching. This cable must not be run in the same conduit as the ignition primary or other wires. A distance of 4 to 6 inches should be maintained between EPC-100 or EPC-150 wiring and other engine wiring. Note that the upper connector on the EPC-100 or EPC-150 controls the stepper valve for single control channel applications and the left bank valve on V-engines.

4.0 POWER SUPPLY

- 4.1 The circuitry of the valve is powered directly by the EPC-100, EPC-150 or the output of the Stepper Motor Controller 691156-1. No additional external power source should ever be connected to the valve.

5.0 FLOW CHARACTERISTICS

- 5.1 See the flow capacity curve, FIG. 4 in the drawings section. The CV of the 690230-1 has been determined by independent laboratory testing using compressed air. The CV of the 690220-1 can be estimated by multiplying the CV number for a given % OPEN from the graph by 0.42. The CV of the 690225-1 can likewise be estimated by multiplying by 0.69.

6.0 GAS VALVE SERVICE AND REPAIR OVERVIEW

- 6.1 The Gas Valve has been designed to provide reliable operation with a minimum amount of maintenance. To ensure optimum performance, periodic inspection and cleaning is necessary. Preventative maintenance issues can be integrated into the current maintenance schedule of the engine. Most maintenance requires little effort and minimal downtime of the valve. Corrective maintenance is to be done when the Gas Control Valve begins to behave erratically. Procedures have been generated to cover most minor issues.

- **External Visual Inspection** – Inspect the exterior of the Gas Control Valve for loose connections, frayed wires or structural damage.
- **Cleaning** – Exterior cleaning will aid in the visual inspection of the external casing and ensure good connections. Mild soapy water can be used as a cleaning agent.
- **Maintenance Log** – To facilitate troubleshooting and to establish service schedules, a maintenance log should be kept on the Gas Control Valve.

Throughout this manual, service parts will be identified by the figure number and item number assigned in the parts list. Items will be referred to by the figure number followed by a hyphen and the item number that it refers to. For example, (2-5) and its position on the Gas Control Valve can be found by locating item 5 on FIG. 2 and looking for its description and part number as identified in the table.

7.0 SERVICING THE GAS CONTROL VALVE

- 7.1 The Altronic Gas Control Valve is set from the factory and generally does not need adjustment, however periodic maintenance may be needed depending on the service application and quality of the fuel passing through the valve. By following the recommended mounting positions and supplying clean gas this valve will provide excellent service.

7.2 The following lists the service kits available for the Gas Control Valve.

- Stepper Motor Assembly Kit P/N 620008
- Throttle Plate Housing Kit P/N 670049
- O-Ring Kit P/N 620009
- Control / Throttle Housing Kit P/N 680008

Other parts are available as individual items.

8.0 DISASSEMBLY OF THE GAS CONTROL VALVE

8.1 This section covers the disassembly of the fuel control valve for purposes of field service or maintenance. This valve was designed to be serviceable while connected to the gas pipeline **providing that the gas flow has been shut off to the valve. Failure to shut off the gas flow can cause a very dangerous situation.** If servicing is to be done with the valve removed from the gas pipeline, then it is recommended that a clean flat work surface be prepared and the proper tool be made available. NOTE: Most of the screws and threads below the cover have a service removable thread locker (Loctite 222) on them which may make them more difficult than usual to remove.

8.2 This is a recommended tool list to disassemble the 690 2XX series Gas Control Valves:

- 3/16" to 1/4" wide slotted screwdriver
- #1 Phillips Head screwdriver
- #2 Phillips Head screwdriver
- 7/16" socket with ratchet and short extension
- 1/16" short arm hex wrench (Allen wrench)
- 9/64" T - handle hex wrench (Allen wrench)
- 5/32" T - handle hex wrench (Allen wrench)

8.3 With the stepper motor in its fully retracted position (valve fully open), remove the four 8-32 seal screws (2-15) that secure the connector to the cover. Next remove the eight 10-32 cap screws (2-14) that fasten the cover to the control housing. Note gasket (2-12) between connector and cover. There is also a gasket (2-11) between the cover and the control housing.

8.4 With the cover (2-3) removed, the inner workings of the valve are now exposed. Keep this area free from contaminants such as excessive dirt and moisture. Removing the four hex head screws (2-13) and the flat washers (2-17) will allow you separate the Control / Throttle Housing Assembly (2-1) from the Port Housing (2-2). Having available a spare Control / Throttle Housing Assembly (2-1) will minimize downtime due the ease of exchanging one larger assembly versus a number of smaller ones. If you are exchanging the Control/Throttle Housing Assembly, skip to section 9.8 for reassembly instructions. If you are not exchanging the Control / Throttle Housing Assembly, it is recommended that you leave the screws in and do not remove it from the Port Housing at this time as this will make further disassembly easier by allowing the Port Housing to hold the Control / Throttle Housing Assembly.

- 8.5 To disassemble the Control/Throttle assembly refer to FIG. 3. With the stepper motor in its fully retracted position, remove the four Phillips-head screws (3-3D) from the bracket. Lift stepper motor assembly taking care not to bend the slider (3-3C) from tilting it against the pin on the shaft lever assembly (3-8). Once the slider is clear of the pin, remove the stepper motor assembly from the Control Housing (3-2).
- 8.6 Remove magnet**(3-10) from magnet holder (3-9) using a straight punch to carefully push the magnet from the magnet holder taking precautions not to damage magnet or exert excessive perpendicular force on the end of the throttle plate shaft (3-1B). Magnet is retained in the magnet holder using silicone rubber adhesive (RTV). Removing any excess amounts of RTV first may make this step easier.
**NOTE: Mark magnet and holder and note orientation to be sure of correct pole alignment on re-installation.
- 8.7 Remove cap screw (3-12) that secures the magnet holder (3-9) to the throttle plate shaft (3-1B) and remove magnet holder.
- 8.8 Loosen (unscrew by at least 1/16") or remove the set screw (3-13) in the shaft lever assembly (3-8) using 1/16 short arm hex wrench. Slide shaft lever assembly up the shaft until it is off of the shaft.
- 8.9 Remove all of the 7/16 hex head screws and washers (3-11, 3-14) and (2-13, 2-17). Lift control housing (3-2) off the port housing (2-2) and note if any o-rings are stuck to the bottom of the control housing. Remove the five o-rings, one (2-9) on the top outside of the throttle plate housing, and four (2-10) on each screw that attaches the control housing to the throttle plate housing.
- 8.10 Remove the throttle plate housing by gripping the shaft with your fingers and pulling up.

9.0 REASSEMBLY OF THE GAS CONTROL VALVE

- 9.1 To reassemble the valve, follow the instructions given. The use of a service removal thread locker (Loctite 222) is recommended on all fasteners.
- 9.2 Replace the throttle plate housing (3-1) into the port housing (2-2), aligning the opening of the throttle plate housing with the hole through the port housing.
- 9.3 Replace the five o-rings, one (2-9) on the outside top of the throttle plate housing and four (2-10) for the screws that attach the throttle plate housing to the control housing (3-2).
- 9.4 Attach the control housing to the port housing (2-2) and throttle plate assembly using the screws (3-11), (2-13) and washers (3-14), (2-17) provided.
- 9.5 Slide the shaft lever assembly (3-8) onto the shaft (3-1B). Align the set screw (3-13) to the flat on the shaft approximately halfway up the flattened area on the shaft.
- 9.6 Replace the magnet holder (3-9) onto the throttle plate shaft (3-1B) and secure it using the cap screw (3-12).

- 9.7 Replace the magnet (3-10) into the magnet holder (3-9) by pressing it in using your thumb. **Be sure to observe the previously marked polarity.** Use a dab of RTV to help secure the magnet.
- 9.8 With the stepper motor in its fully retracted position, carefully insert the pin into the slot on the slider (3-3C). Secure the stepper motor assembly with the four Phillips head screws (3-3D).
- 9.9 Replace the four 8-32 seal screws (2-15) which secure the connector to the cover (x-x) taking care to properly mount the connector gasket (2-12) between the connector and the cover. Replace the cover using the eight 10-32 cap screws (2-14) being careful to properly mount the gasket (2-11) between the cover and the control housing. NOTE: The indicating arrow on the cover should now be in the open position.
- 9.10 Before returning the valve to service, the valve should be thoroughly leak tested using a soapy water solution. Brush a small amount of this solution onto the area to be tested. A constant bubbling of the liquid indicates a leak. Do not submerge the valve in the test solution. Carefully check the area around the cover gasket and around the connector. Also check the interface between the port housing and the control assembly for leaks.

FIG. 1 FUEL VALVE DETAIL

MEDIA COMPATIBILITY

- 6061 ALUMINUM BLACK ANODIZED BODY WITH STAINLESS STEEL BUTTERFLY AND SHAFT. CORROSION RESISTANT STEPPER MOTOR

ELECTRICAL SPECIFICATION

- 24 VOLTS @ 5 WATTS MAX.

MAX. WORKING PRESSURE

- 50 PSIG

MAX. OPERATING TEMPERATURE

- -40°F TO 185°F

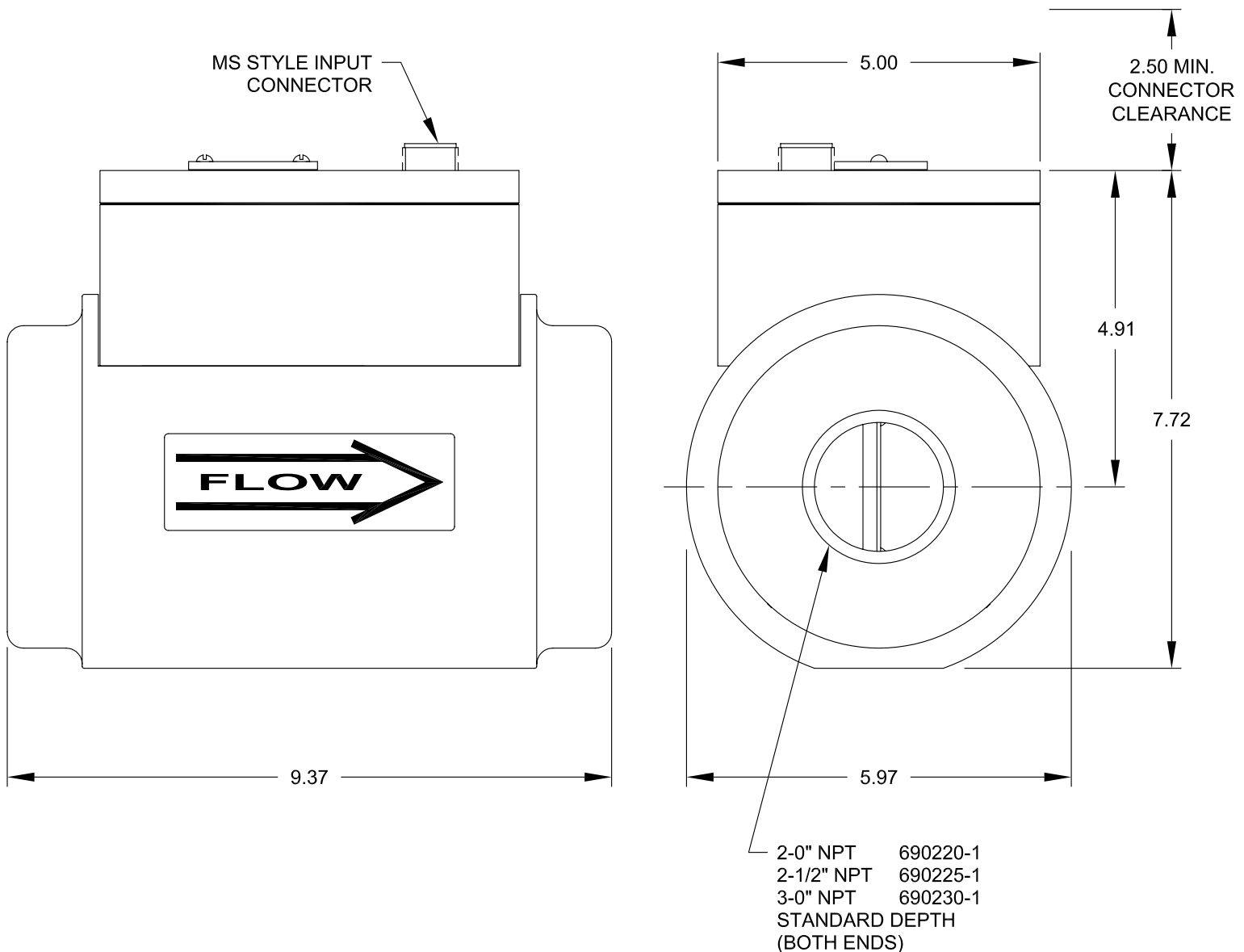

FIG.2 PART IDENTIFICATION

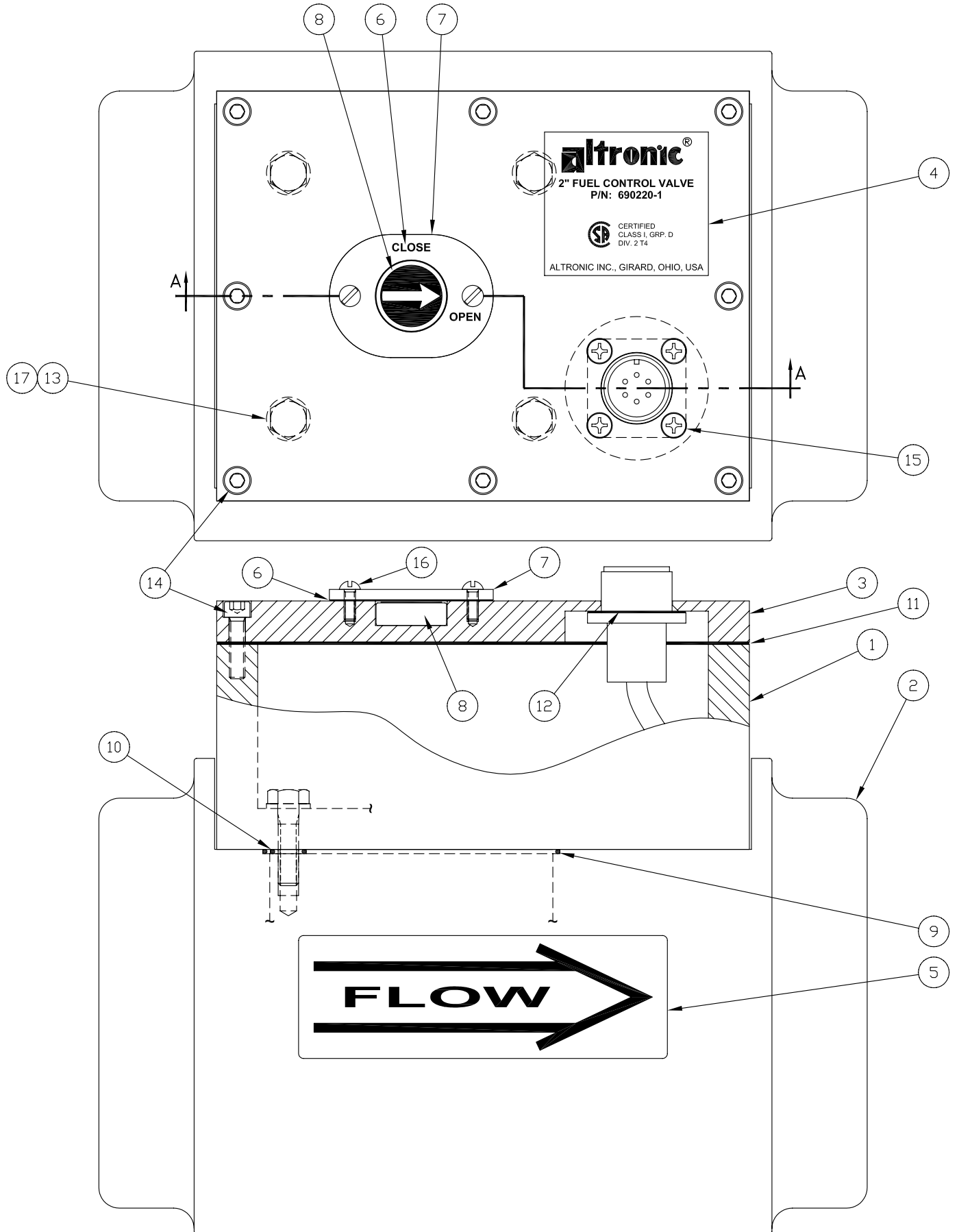
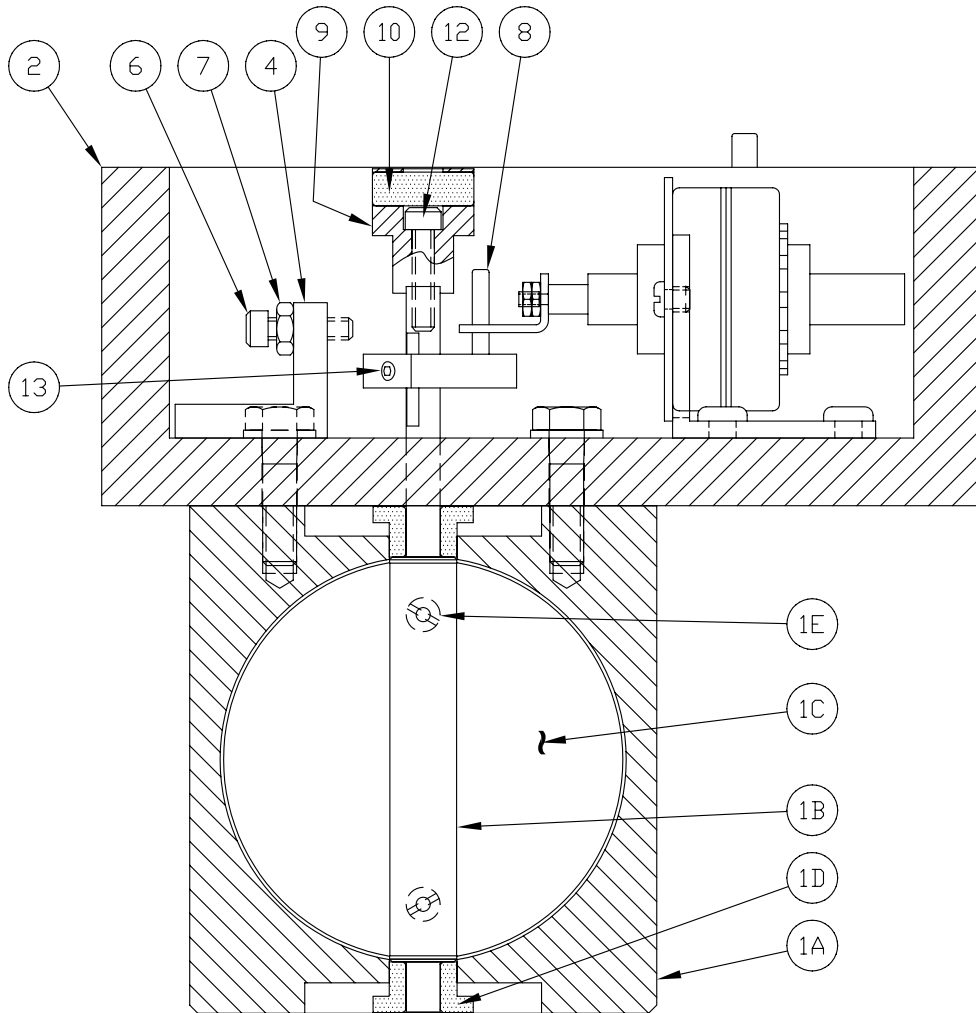
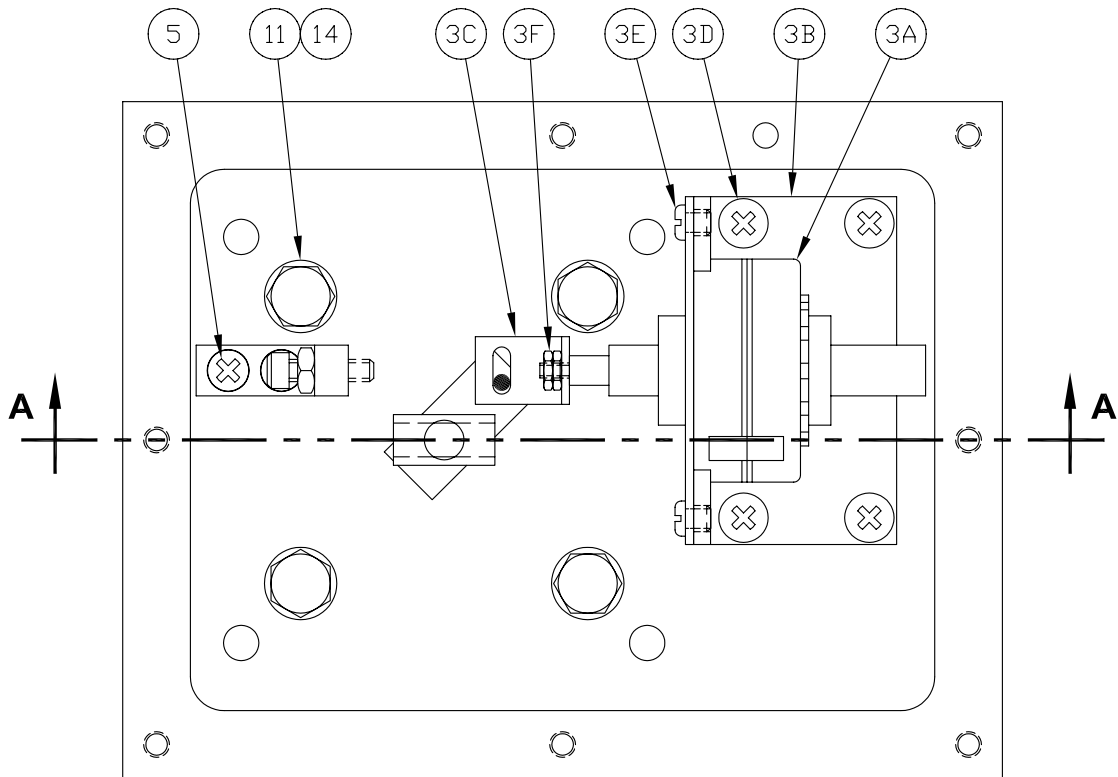

FIG. 2 - PARTS IDENTIFICATION

ITEM NO.	QUANTITY	PART NO.	DESCRIPTION
1	1	680008	Control / Throttle Housing Assembly
2	1	610909	Port Housing
3	1	610910	Cover
4	1	602586	Label, P/N
5	1	810005	Label, Flow
6	1	602587	Label, Open / Close
7	1	310365	Cover, Valve Position Indicator
8	1	680009	Valve Position Indicator Assembly
9	1	810052	O-ring
10	4	810024	O-ring
11	1	610923	Gasket, Cover
12	1	501335	Gasket, Connector
13	4	902629	Screw, 1/4-20 x 1, Hex
14	8	801033	Screw, 10-32 x 3/4, Cap
15	4	902615	Screw, 8-32 x 1/4, Ft Hd Seal
16	2	902064	Screw, 6-32 x 3/8, Rd Hd
17	4	902577	Washer, .535 O.D. x .257 I.D. Flat

NOTE: 620009 O-ring kit consists of qty. 1 of item 9 and qty. 4 of item 10.

FIG.3 PART IDENTIFICATION



SECTION A-A

FIG. 3 - PARTS IDENTIFICATION

ITEM NO.	QUANTITY	PART NO.	DESCRIPTION
1	1	670049	Throttle Plate Housing Kit
1A	1	610911	Housing, Throttle Plate
1B	1	610912	Shaft, Throttle Plate
1C	1	610913	Throttle Plate
1D	2	610914	Bushing, Shaft
1E	2	902560	Screw, 6-32 x 1/4
2	1	610915	Control Housing
3	1	620008	Stepper Motor Kit
3A	1	620001-3	Stepper Motor / Connector Ass'y
3B	1	610917	Bracket
3C	1	610918	Slider
3D	4	902642	Screw, 10-32 x 3/8 Pan Hd Ph
3E	2	902598	Screw, 6-32 x 3/16 Pan Hd
3F	2	902582	Nut, 4-40 Hex
4	1	610921	Throttle Stop
5	2	902687	Screw, 8-32 x 1/2 Ft Hd Ph
6	1	801001	Screw, 8-32 x 5/8 Cap
7	1	901679	Nut, 8-32
8	1	670050	Shaft Lever Assembly
9	1	610920	Magnet Holder
10	1	801085	Magnet
11	4	902629	Screw, 1/4 - 20 x 1 Hex Hd
12	1	902686	Screw, 8-32 x 3/4 Cap
13	1	902685	Screw, 6-32 x 1/4 Set, Ft Pt
14	4	902577	Washer, .535 O.D. x .257 I.D.

FIG.4 CV OF VALVE

