

**WARNING: DEVIATION FROM THESE INSTALLATION INSTRUCTIONS MAY LEAD TO IMPROPER ENGINE OPERATION WHICH COULD CAUSE PERSONAL INJURY TO OPERATORS OR OTHER NEARBY PERSONNEL.**

## **1.0 SYSTEM DESCRIPTION**

- 1.1 The Altronic CPU-95 Ignition system has been designed for application in conjunction with the Caterpillar Timing Control Module on natural gas fueled engines. This system is designed to replace both the Altronic III and the Altronic Interface Box. New features include advanced spark energy control, primary and spark diagnostics, self diagnostics, pickup diagnostics and serial communications. The function of the Caterpillar Timing Control Module and SI Controller remains unchanged and no reprogramming of that system is required. The ignition system consists of two main parts: an engine mounted Ignition Module (791955-16) and an optional user interface Display Module (791902-2).
- 1.2 The specific applications for this CPU-95 Ignition are:
  - Caterpillar G3508 with SI controller and 183 tooth ring gear
  - Caterpillar G3512 with SI controller and 183 tooth ring gear
  - Caterpillar G3516 with SI controller and 183 tooth ring gear
- 1.3 The optional Display Module has an alphanumeric 16-character x 2-line back-lit LCD display that shows the operating status, engine RPM, energy level and single or double-striking mode. Additional display screens show set-up and diagnostic information.
- 1.4 To allow for a simple and economical upgrade from the existing Altronic III with Interface Box, the CPU-95 utilizes existing Altronic coils, typically part number 591012, and the same connections to the Caterpillar Timing Control Module (TCM). The addition of a Hall-effect pickup and trigger magnet is required as a 4-cycle trigger.
- 1.5 Power requirement is 24 Vdc, 5 ampere nominal for typical applications. See section 7.2 for details.

**WARNING: THE IGNITION SYSTEM MUST BE CONFIGURED PRIOR TO USE ON AN ENGINE. REFER TO SECTION 9.7 OF CPU-95 OI-C TO VIEW THE CURRENT CONFIGURATION. REFERENCE FORM CPU-95 PI FOR INSTRUCTIONS DESCRIBING HOW TO CONFIGURE THE IGNITION SYSTEM. VERIFY EEPROM PROGRAMMING PRIOR TO STARTING ENGINE.**

## **2.0 SYSTEM COMPONENTS**

- 2.1 The system consists of an Ignition Module, a Display Module, wiring harnesses, a Hall-effect pickup and trigger magnet, and an ignition coil for each spark plug. The system is designed to operate in conjunction with the Caterpillar Timing Control Module (TCM) which provides timing and control signals required for operation. Refer to drawing 709 976 for a complete system overview.
- 2.2 For non-hazardous area operation, use one of the Altronic unshielded epoxy coils, 591012 or 591018. For hazardous area operation, use the optional shielded coil series 501061-S or 591010-S or integral coils 591007, 591011A or 591011B with shielded primary cable assemblies 593022 or 593027.

## **3.0 MOUNTING THE IGNITION MODULE**

- 3.1 Refer to drawing 799 050 for physical dimension details. The current mounting location of the Ignition Interface module is the preferred location for this unit. If a new location is desired select it to meet the following requirements:
  - On the engine.
  - Within 50 ft. (15 m) of the Display Module.
  - Within 7 ft. (2 m) of the primary junction box.
  - The front door of the Ignition Module should be easily accessible and free to swing open.
  - The maximum ambient temperature must not exceed 150°F (65°C).
- 3.2 The Ignition Module enclosure should be fastened securely to a rigid engine bracket using the shock mounts provided. NOTE: The enclosure width is 1 inch (25.4mm) larger than the existing Altronic Interface Box, ½ inch (12.7mm) on each side.

## **4.0 MOUNTING THE DISPLAY MODULE**

- 4.1 Mount the Display Module inside a control panel or to a suitable flat surface preferably off the engine in such a manner as to minimize exposure to vibration. The Display Module should be mounted so that the display is at a convenient viewing height. Refer to drawing 799 051 for mounting dimensions. A NEMA 3R housing (720004-1) is also available as an alternative mounting option for the Display Module (see drawing 799 048).
- 4.2 The Display Module should be mounted within 50 feet (15 m) of the Ignition Module which is to be mounted on the engine.
- 4.3 Operating temperature range is –40°F to 158°F (–40°C to 70°C). Humidity specification is 0-95%, non-condensing. Housed in an aluminum weatherproof enclosure, the CPU-95 Display Module is splash resistant; however, the mounting site should provide as much protection from inclement weather as is practical. Avoid mounting the LCD display and keypad in direct sunlight.

## **5.0 MOUNTING THE HALL-EFFECT PICKUP AND TRIGGER MAGNET**

- 5.1 The Hall-effect pickup (591014-x) senses a magnet which must be fixed at the proper angular position of the cam gear.
- 5.2 The leading edge of the Hall-effect pickup signal represents the reset signal for the ignition in manual/startup timing mode. In the electronic timing mode, the Hall-effect signal is used to select the reset pulse from the TCM that occurs during the compression stroke (the TCM generates reset pulses during both the compression stroke and the exhaust stroke).
- 5.3 The Hall-effect signal leading edge must occur at least 12 degrees ahead of the most advanced desired electronic timing of the first cylinder. The Hall-effect signal falling edge must occur no earlier than the most retarded desired timing in electronic mode. To meet these requirements, mount the 720002 magnet on the end of the camshaft at a radius of 0.75 to 1.0 inch (19.0 to 25.4mm) from the center of the cam.
- 5.4 Rotate the engine to the compression stroke of cylinder number one (1). Then adjust the engine to align the timing mark to indicate twelve (12) degrees advanced of the most advanced desired electronic timing. With this setting of the engine, the Hall-effect pickup should be turned on by the magnet. The H.E. Pickup indicator (LED) in the Ignition Module will light when the pickup is activated. The H.E. Pickup indicator should remain on until the engine is rotated to the most retarded desired electronic timing.
- 5.5 The Hall-effect pickup dimensions are shown on drawing 591014. The air gap between the Hall-effect pickup and trigger magnet must not exceed .040" (1.0mm).

## **6.0 IGNITION MODULE ELECTRICAL HOOKUP (REFER TO WIRING DIAGRAM 709 979)**

- 6.1 The left-most 5-pin terminal strip at the bottom of the Ignition Module provides the serial interface to the Ignition Module. Signals available at this terminal strip are used to communicate with a Display Module, or with a custom PC program using the PC serial port. Power (24 Vdc) is also provided in this terminal strip which should be used to power the Display Module. See diagram 709 979 for terminal assignments.
- 6.2 The left-center 4-pin terminal strip at the bottom of the Ignition Module provides the interface for the cycle trigger input signal from the Hall-effect pickup. See diagram 709 979 for terminal assignments.

- 6.3 The right-center 2-pin terminal strip at the bottom of the Ignition Module provides the connection for the 24 volt power source. See diagram 709 979 for terminal assignments. The ignition system can be powered in one of the following ways:
- A. 24 volt battery with charger ( 5 amps minimum output).
  - B. DC power supply capable of furnishing 24-28 Vdc, 5 amps.
- NOTE: The negative (-) of the 24 Vdc supply MUST BE COMMON WITH ENGINE GROUND.

**WARNING: ALTHOUGH THE DEVICE HAS INTERNAL PROTECTIVE FUSES (6.3 AMP), TWO EXTERNAL 10 AMP FUSES NEAR THE POWER SOURCE ARE RECOMMENDED FOR THE PROTECTION OF ENGINE AND BUILDING WIRING. THIS WILL REDUCE THE POSSIBILITY OF A FIRE OCCURRING IN THE EVENT OF A SHORT CIRCUIT IN THE WIRING. SEE DRAWING 709 961.**

IMPORTANT: For proper operation of the CPU-95 system, voltage and current supplied must be sufficient during all selected modes of operation. Drawing 709 961 provides these details regarding the DC power hookup:

1. CURRENT DRAW PER SYSTEM - formula varies depending on number of outputs used, engine cycle and RPM, and the use of the multi-strike feature.
  2. MINIMUM WIRE GAUGE REQUIREMENTS - Chart 1 of drawing 709 961 gives the requirement vs. the length of run between the power source and the CPU-95 Ignition Module.
  3. MULTIPLE ENGINE INSTALLATIONS - Multiply current required per system by the number of engines. Where more than one engine is powered from a common power source, see Chart 2 of drawing 709 961 for the minimum wire size required.
- 6.4 The 10-pin connector on the right, bottom side of the Ignition Module is designed to accept the existing Caterpillar Timing Control Module interface harness. This connection provides signals critical to the operation and control of the Ignition Module. These signals include, conditioned ring-gear pulses, reset pulses used for timing control in automatic mode and a manual/automatic mode control signal. The pin-out of the connector is given on drawing 799 050. See the Caterpillar engine manual for a detailed description of these signals.
- Note 1: Unlike the Altronic III system which is capable of running the engine without a connection to the Timing Control Module, the CPU-95 system must have correct signals from the TCM in order to function..
- Note 2: The magnetic pickup used by the TCM may require a closer gap than currently specified to provide suitable gear-tooth signals at engine cranking speeds. With the Altronic III system, the gear tooth signal was required only for operation above 500 RPM. With the CPU-95 system, the pickup signal must function correctly at cranking RPM.
- Note 3: The safety shutdown of the ignition system and fuel supply is controlled by the Caterpillar SI Control System, the same as it was with the Altronic III and Interface Box.

## **7.0 DISPLAY MODULE ELECTRICAL HOOKUP (REFER TO DRAWING 709 975)**

- 7.1 **GENERAL** - Take care not to damage the wiring insulation and take precautions against damage from vibration, abrasion or liquids in conduits. In addition, DO NOT run low voltage power, current loop, or communications wires in the same conduit as the ignition wiring or other high energy wiring such as AC line power, etc. Keep wires at least 12 inches (30cm) away from all high voltage wiring.
- 7.2 **POWER** - Connect the power input wires to terminals 1(+) and 2(-); power requirement is 24 Vdc, 250 mA max. The power minus terminal (-) of the Display Module must be common with the power minus terminal (-) of the Ignition Module. DO NOT ground this device directly to the ignition system common coil ground.
- 7.3 **COMMUNICATIONS** - The Display Module communicates to the Ignition Module via the two serial RS485 communication wires. Use a four conductor shielded cable of fine gauge stranded wire for connection of both the power and the RS-485. Connect the shield to the terminal marked SHIELD in the Ignition Module only.

## **8.0 PRIMARY WIRING**

- 8.1 The main wiring harness (293023-x, 293026-x, 793012-x, 793015-x or 793022-x) connects the Ignition Module to the engine junction box or ignition coils. Refer to drawing 509 025 if it is desired to shorten the conduit length of the harness. Insert the connector into the CPU-95 Ignition Module receptacle and tighten hand-tight; then carefully tighten an additional one-sixth turn with a wrench.

Refer to the chart below or drawing 709 978 for the hookup to the particular Caterpillar G3500 engine:

<b>HARNESS:</b>	<b>A - B - C - D - E - F - K - L - M - N - P - R - S - T - U - V</b>
<b>G3508:</b>	<b>1 - 2 - 7 - 3 - 4 - 5 - 6 - 8</b>
<b>G3512:</b>	<b>1 -12 - 9 - 4 - 5 - 8 -11 - 2 - 3 -10 - 7 - 6</b>
<b>G3516:</b>	<b>1 - 2 - 5 - 6 - 3 - 4 - 9 -10 -15 -16 -11 -12 -13 -14 - 7 - 8</b>

- 8.2 Connect the harness leads in the junction box in accordance with the engine's firing order. The leads from the junction box corresponding to the above system outputs connect to the ignition coil positive (+) terminals. The "J" lead and the common coil ground lead(s) connecting the negative (-) terminals of the ignition coils must be grounded to the engine in the junction box. Make each ground connection in the junction box to a separate bolt so that the ground connections are not stacked on top of each other. Run a separate common ground lead for each bank. Refer to wiring diagram 709 977 for coil connection details.
- 8.3 Primary wire should be no. 16 AWG stranded, tinned copper wire. The insulation should have a minimum thickness of .016" (0.4mm) and be rated 105°C or higher. Irradiated PVC or polyolefin insulations are recommended. Altronic primary wire number 503188 meets these specifications. All primary wiring should be protected from physical damage and vibration. All unused primary wires should be individually taped so that they are insulated from ground and each other.

## **9.0 SHUTDOWN WIRING**

- 9.1 The "G" lead in the output harness is provided to stop the ignition and to power existing ignition powered instruments. This lead is open for normal operation and is connected to engine ground for shutdown. This lead can also be used for oscilloscope analysis.

**WARNING:** Please note the following application limitations between the CPU-95 ignition system and these Altronic instruments:

DO-3300  
DTO-1010  
DT/DTH/DTO/DTHO-1200  
DT/DTH/DTO-3200  
DTUO-4200

The above Altronic ignition-powered tachometers and overspeed devices will NOT function correctly with any CPU-95 system operating in the Double-Strike mode.

**NOTE:** Tachometer and overspeed functions are provided by the CPU-95 Display Module; see sections 4.0 and 9.4 of operating instructions form CPU-95 OI. If a separate device is needed, Altronic models DSG-1201DU/DUP or DTO-1201P will function with all CPU-95 systems.

## **10.0 SECONDARY WIRING**

- 10.1 Mount the ignition coils as close as possible to the engine spark plugs consistent with a secure mounting and avoidance of temperatures in excess of 185°F (85°C).
- 10.2 The spark plug leads should be fabricated from silicone insulated 7 mm cable with suitable terminals and silicone spark plug boots. The use of leads with resistor spark plug boots (Altronic series 5932xx-xx) is recommended to minimize interference from emitted RFI on the operation of other nearby electronic equipment. Another option is the use of suppression ignition cable (Altronic part no. 503185). It is also essential to keep spark plug leads as short as possible and in all cases not longer than 24 inches (600 mm). Spark plug leads should be kept at least 2 inches (50 mm) away from any grounded engine part. In deep spark plug wells, use rigid insulated extenders projecting out of the well.
- 10.3 The use of a clear silicone grease such as Dow Corning DC-4, G.E. G-623 or GC Electronics Z5, is recommended for all high-tension connections and boots. This material helps seal out moisture and prevent corrosion from atmospheric sources.

## **DRAWINGS SECTION:**

### **INSTALLATION DRAWINGS:**

509 025	SHIELDED HARNESS CONDUIT LENGTH ADJUSTMENT
709 961	DC POWER HOOKUP
709 976	IGNITION SYSTEM BASIC LAYOUT
709 977	COIL WIRING DIAGRAM
709 978	HOOKUP DIAGRAM, IGNITION MODULE 791955-16
709 979	WIRING DIAGRAM, IGNITION MODULE 791955-16
709 975	WIRING DIAGRAM, DISPLAY MODULE 791902-2

### **DIMENSIONAL DRAWINGS:**

260 604	MAGNET ASSEMBLY SALES DRAWING
720 002	MAGNET ASSEMBLY SALES DRAWING
591 014	HALL-EFFECT PICKUP SALES DRAWING
799 050	IGNITION MODULE MOUNTING DIMENSIONS
799 051	DISPLAY MODULE MOUNTING DIMENSIONS
799 048	NEMA 3R ENCLOSURE MOUNTING DIMENSIONS





D.C. POWER SOURCE

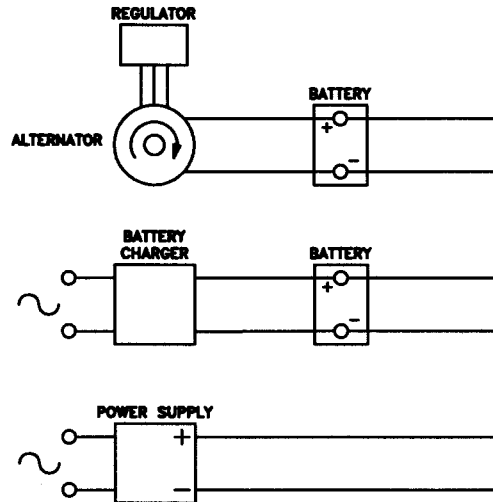

POWER SUPPLY SPEC: 5 AMP CONTINUOUS.

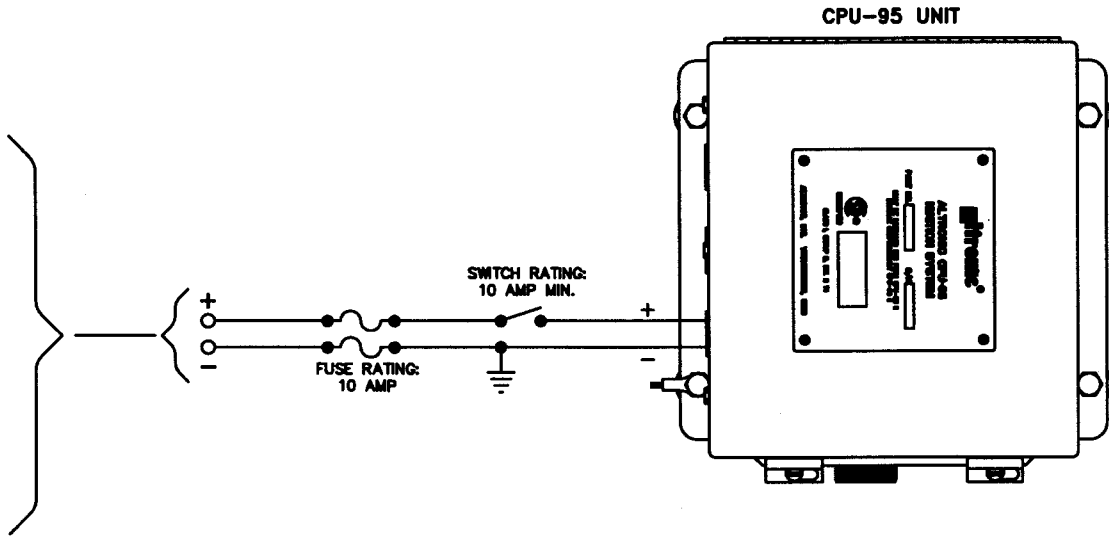

1. IT IS RECOMMENDED THAT EACH SYSTEM BE CONNECTED SEPARATELY BACK TO THE POWER SOURCE. USE CHART 1 TO DETERMINE THE WIRE SIZE (GAUGE) REQUIRED.

2. IF MULTIPLE UNITS ARE POWERED FROM A SOURCE LOCATED IN A SEPARATE BUILDING, USE CHART 2 TO DETERMINE THE WIRE SIZE (GAUGE) REQUIRED BETWEEN THE POWER POINT IN THE ENGINE ROOM; THEN USE CHART 1 TO DETERMINE THE WIRE SIZE REQUIRED FROM THIS COMMON POINT TO EACH IGNITION MODULE.

AVERAGE CURRENT DRAW	4-CYCLE	2-CYCLE
SINGLE-STRIKE MODE	N X RPM 12,500	N X RPM 6,250
DOUBLE-STRIKE MODE	N X RPM 8,000	N X RPM 4,000

N = NUMBER OF OUTPUTS USED.  
MULTIPLY BY NUMBER OF ENGINES FOR TOTAL REQUIREMENT.

OPERATING VOLTAGE REQUIREMENT:

STARTING:	20 VDC MIN.
RUNNING:	24-28 VDC

DISTANCE IN FEET	MINIMUM WIRE GAUGE
UP TO 25	16 AWG
26-40	14 AWG
41-65	12 AWG
66-100	10 AWG
101-160	8 AWG

CHART 1

NO. OF SYSTEMS X DISTANCE IN FEET	MINIMUM WIRE GAUGE
26-40	14 AWG
41-65	12 AWG
66-100	10 AWG
101-160	8 AWG
161-250	6 AWG
251-400	4 AWG

CHART 2

NOTE: ABOVE 400, USE MULTIPLE PAIRS OF WIRES FROM THE POWER SOURCE TO THE ENGINE ROOM.

REVISIONS				TOLERANCES (EXCEPT AS NOTED)		ALTRONIC INC.		
NO.	DATE	BY	DESCRIPTION	DECIMAL	FRAC TIONAL	TITLE		PART NUMBER
1				.XXX - ±.005		DC POWER HOOKUP CPU-95 IGNITION SYSTEM		
2				.XX - ±.010		DRAWN BY	WTP	SCALE .888
3						CHECKED BY		DATE 1-30-96
4						APPROVED BY		709 961
5								

KEYPAD ADJUSTABLE TIMING, MANUAL OR INDIVIDUAL  
 KEYPAD ADJUSTABLE ENERGY, GLOBAL  
 KEYPAD SELECTED SINGLE OR MULTI-STRIKE FIRING  
 KEYPAD ADJUSTABLE OVERSPEED SETTING  
 KEYPAD SELECTED TEST MODE, GLOBAL OR INDIVIDUAL  
 DISPLAYS OPERATING MODE, RPM, AND STATUS  
 DISPLAYS DIAGNOSTIC FAULT MESSAGES  
 24 VDC NOMINAL INPUT POWER

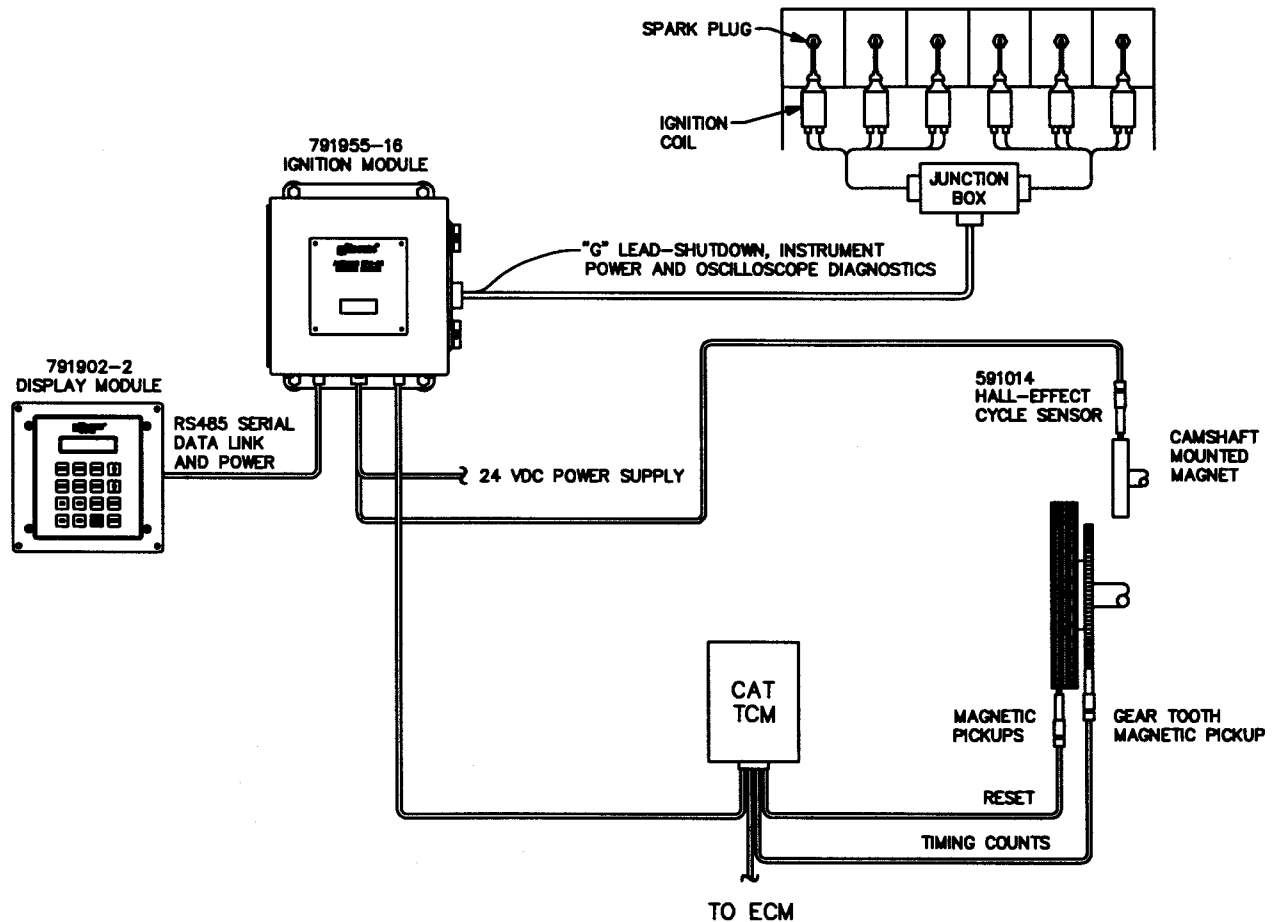

REVISIONS				TOLERANCES (EXCEPT AS NOTED)		ALTRONIC INC.			
NO.	DATE	BY	DESCRIPTION	DECIMAL		TITLE			
1				.XXX	±.005	SYSTEM DIAGRAM, CPU-95 IGNITION SYSTEM		PART NUMBER	
2				.XX	±.010				
3				FRACTIONAL		DRAWN BY	GET	SCALE	NONE
4				MATERIAL		CHECKED BY		DATE	5-12-97
5						APPROVED BY			709 976

709 976

\* CLASS I, GROUP D, DIV. 2 CERTIFIED SYSTEM.  
UNSHIELDED SPARK PLUG AND LEAD MAY BE  
USED WHERE SUCH RATING IS NOT REQUIRED.

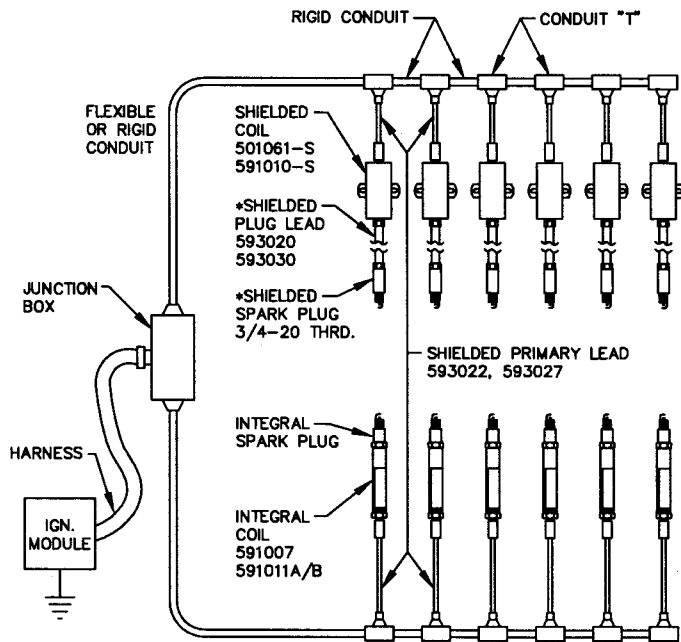

NOTE:  
IGNITION MODULE  
MUST BE GROUNDED

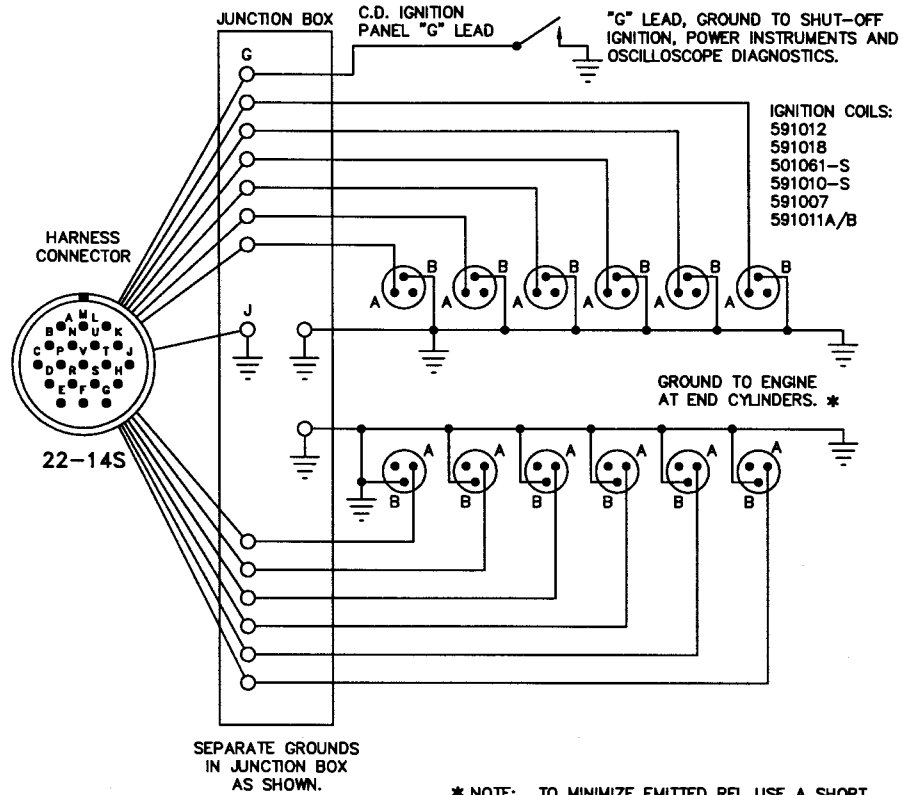

\* NOTE: TO MINIMIZE EMITTED RFI, USE A SHORT  
GROUND LEAD AS SHOWN ON EACH COIL  
FROM THE NEGATIVE (B) TERMINAL TO  
ENGINE GROUND.

REVISIONS				TOLERANCES (EXCEPT AS NOTED)		ALTRONIC INC.		
NO.	DATE	BY	DESCRIPTION	DECIMAL	FRACTIONAL	TITLE		PART NUMBER
1				.XXX - ±.005		COIL WIRING DIAGRAM		
2				.XX - ±.010		CATERPILLAR 3500 SERIES ENGINES		
3						DRAWN BY	WTP	SCALE NONE
4						CHECKED BY	DATE	5-12-97
5						APPROVED BY		709 977

ENGINE MODEL	MEMORY CODE	IGNITION SYSTEM FIRING ORDER	
G3508	H4A183.G	A - B - C - D - E - F - K - L	CONNECTOR PIN
		1 - 2 - 7 - 3 - 4 - 5 - 6 - 8	ENGINE CYLINDER
G3512	L4A183.G	A - B - C - D - E - F - K - L - M - N - P - R	CONNECTOR PIN
		1 - 12 - 9 - 4 - 5 - 8 - 11 - 2 - 3 - 10 - 7 - 6	ENGINE CYLINDER
G3516	P4T183.G	A - B - C - D - E - F - K - L - M - N - P - R - S - T - U - V	CONNECTOR PIN
		1 - 2 - 5 - 6 - 3 - 4 - 9 - 10 - 15 - 16 - 11 - 12 - 13 - 14 - 7 - 8	ENGINE CYLINDER

791955-16 IGNITION MODULE

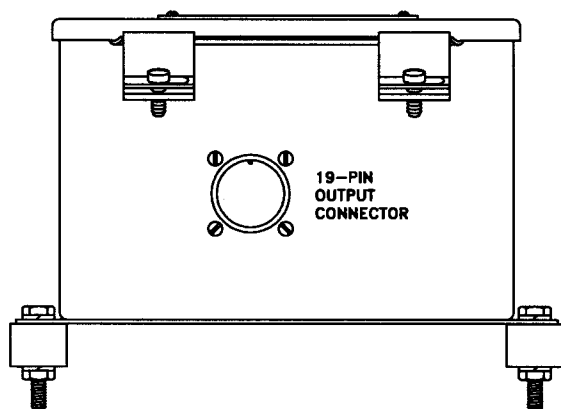

REVISIONS				TOLERANCES (EXCEPT AS NOTED)		ALTRONIC INC.			
NO.	DATE	BY	DESCRIPTION	DECIMAL XXX - ±.005 XX - ±.010	FRACTIONAL	TITLE	DRAWN BY	SCALE	PART NUMBER
1						791955-16 IGNITION MODULE HOOK-UP DIAGRAM	WTP	NONE	709 978
2							CHECKED BY	DATE	
3							APPROVED BY		
4									
5									

709 978



709 975

791955-16  
IGNITION MODULE

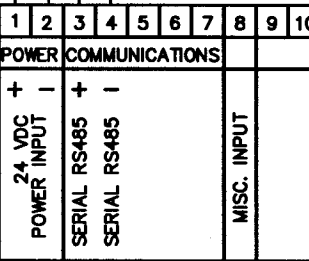
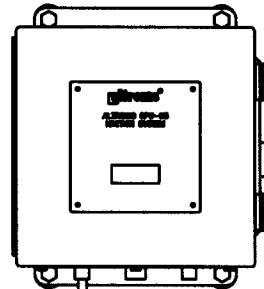

DISPLAY MODULE

NOTE:

1. INPUT POWER REQUIREMENT FOR DISPLAY MODULE IS 24 VDC 150 mA NOMINAL.
2. POWER GROUNDS FOR THE DISPLAY MODULE AND THE IGNITION MODULE MUST BE AT THE SAME GROUND POTENTIAL FOR PROPER OPERATION OF THE RS485 COMMUNICATIONS.
3. USE SHIELDED CABLE FOR RS485 CONNECTIONS. CONNECT SHIELD IN IGNITION MODULE.
4. 791902-2 DISPLAY MODULE OPERATES EXCLUSIVELY WITH 791955-16 IGNITION MODULE.

REVISIONS

NO.	DATE	BY	DESCRIPTION
1			
2			
3			
4			
5			

TOLERANCES  
(EXCEPT AS NOTED)

DECIMAL  
.XXX - ±.005  
.XX - ±.010

FRACTIONAL

MATERIAL

ALTRONIC INC.

TITLE  
WIRING DIAGRAM,  
791902-2 DISPLAY MODULE

DRAWN BY GET SCALE NONE PART NUMBER

CHECKED BY DATE 5-12-97

APPROVED BY

709 975







**SPECIFICATIONS:**

SUPPLY VOLTAGE: 5 TO 8 VOLTS D.C.

SUPPLY CURRENT: 50 mA. MAX.

OUTPUT VOLTAGE @ 5 mA: SUPPLY VOLTAGE MINUS 1.0 VOLT MAX.

OUTPUT CURRENT SOURCING: 10 mA. MAX.

STORAGE AND OPERATING TEMP.: -40°C TO +125°C  
-40°F TO +257°F

ENCAPSULATED IN GLASS-FILLED EPOXY SUITABLE FOR ENGINE OIL OR OTHER NON-CONDUCTIVE MEDIA ONLY.

MAXIMUM OPERATING PRESSURE: 50 psi DIFFERENTIAL

**TYPICAL OUTPUT WAVEFORM**

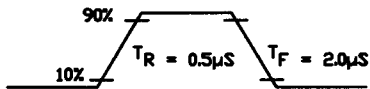

TRIGGERED BY THE NORTH POLE OF MAGNET 5 VOLT SUPPLY 1KΩ LOAD

**SCHEMATIC**

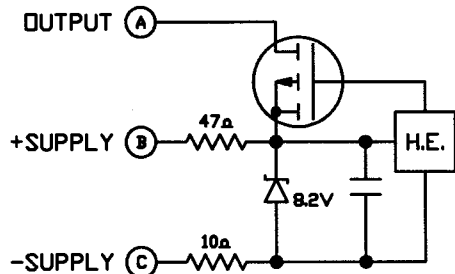

ALTRONIC P/N	T	L
591 014-2	2.50"/63,5mm	4.05"/102,8mm
591 014-4	4.50"/114,3mm	6.05"/153,7mm

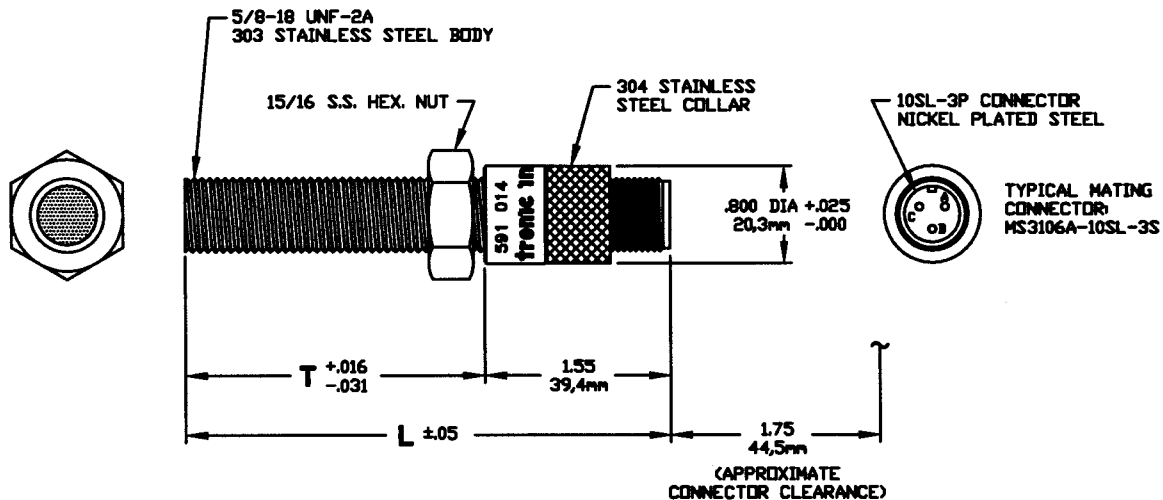

**NOTE:**

1. NORTH POLE OF MAGNET MUST FACE SENSING END WITH AIR GAP OF .030/.040 (.76/1.0).
2. CENTERLINE OF MAGNET'S ROTATION MUST RUN THROUGH CENTERLINE OF PICKUP.
3. SUITABLE MAGNETS: 720 001, 720 002, 260 604 OR 790 xxx SERIES MAGNET DISC.
4. SUITABLE HARNESS: 593 055.

**REVISIONS**

NO.	DATE	BY	DESCRIPTION
1	10-8-90	WTP	REDRAWN ON CAD
2	8-6-92	WTP	UPDATED TITLE
3	11-5-96	WTP	ECN 960134
4			
5			

TOLERANCES (EXCEPT AS NOTED)		ALTRONIC INC.	
DECIMAL		TITLE	SALES DRAWING, HALL EFFECT PICKUP
FRACTIONAL		DRAWN BY	DWA
MATERIAL		CHECKED BY	DATE 1-26-88
		APPROVED BY	PART NUMBER 591 014

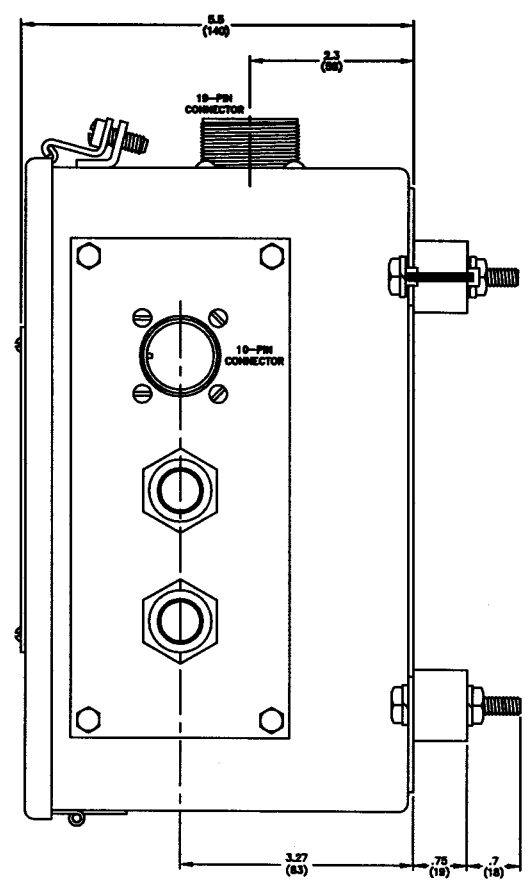
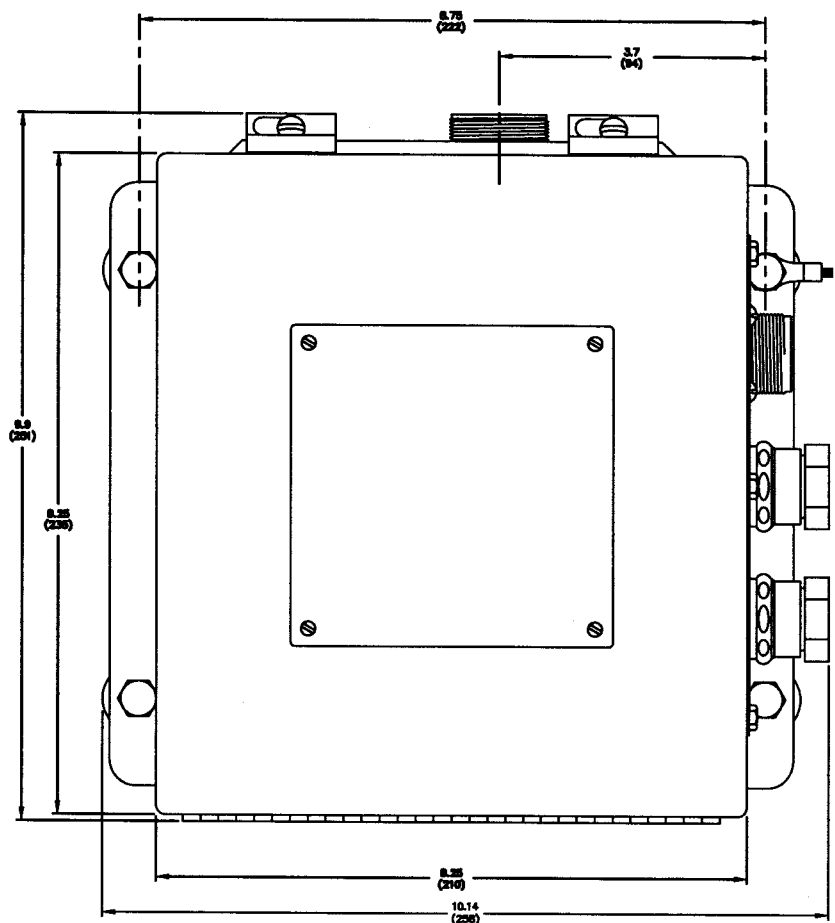

10-PIN CONNECTOR		19-PIN CONNECTOR	
PIN #	DESCRIPTION	PIN #	DESCRIPTION
A	+ FIRING PLS	A	OUTPUT 1
B	GROUND	B	OUTPUT 2
C	+ MANUAL OVERRIDE INPUT	C	OUTPUT 3
D	SIGNAL COMMON RETURN	D	OUTPUT 4
E	+ GEAR TOOTH INPUT	E	OUTPUT 5
F	SIGNAL COMMON RETURN	F	OUTPUT 6
G	+ RESET INPUT	G	SHUTDOWN LEAD
H	SIGNAL COMMON RETURN	H	NOT USED
I	-	J	GROUND
J	-	K	OUTPUT 7
		L	OUTPUT 8
		M	OUTPUT 9
		N	OUTPUT 10
		P	OUTPUT 11
		R	OUTPUT 12
		S	OUTPUT 13
		T	OUTPUT 14
		U	OUTPUT 15
		V	OUTPUT 16

DIMENSIONS IN INCHES AND (MILLIMETERS)

REVISIONS				TOLERANCES (UNLESS OTHERWISE SPECIFIED)		ALTRONIC INC.				
NO.	DATE	BY	DESCRIPTION	DIMENL	FINISH	TITLE				
1				.0001	AS BUILT	SALES DRAWING				
2				.0005	AS BUILT	CPU-65 UNIT 791955-16				
3				.001	AS BUILT	DRWN BY	WTP	SCALE	.008	PART NUMBER
4						CHKD BY		DATE	5-12-87	799 050
5						APPROVED BY				

**SPECIFICATIONS:**

**POWER:** 24 VDC @ 150 mA NOMINAL, 32 VDC @ 250mA MAX.  
**ENCLOSURE:** WEATHERPROOF, POWDER COATED ALUMINUM  
**FIELD CONNECTIONS:** PLUG-IN TERMINAL STRIPS ON BACK

- CONTROL INPUTS:**
1. RS485 SERIAL COMMUNICATIONS PORT
  2. MISCELLANEOUS INPUT - ONE STEP RETARD (DEFAULT), ALSO MULTI-STRIKE, MAX. ENERGY LEVEL (CONFIGURED THROUGH P.C.)
  3. 4-20 mA CURRENT LOOP INPUT

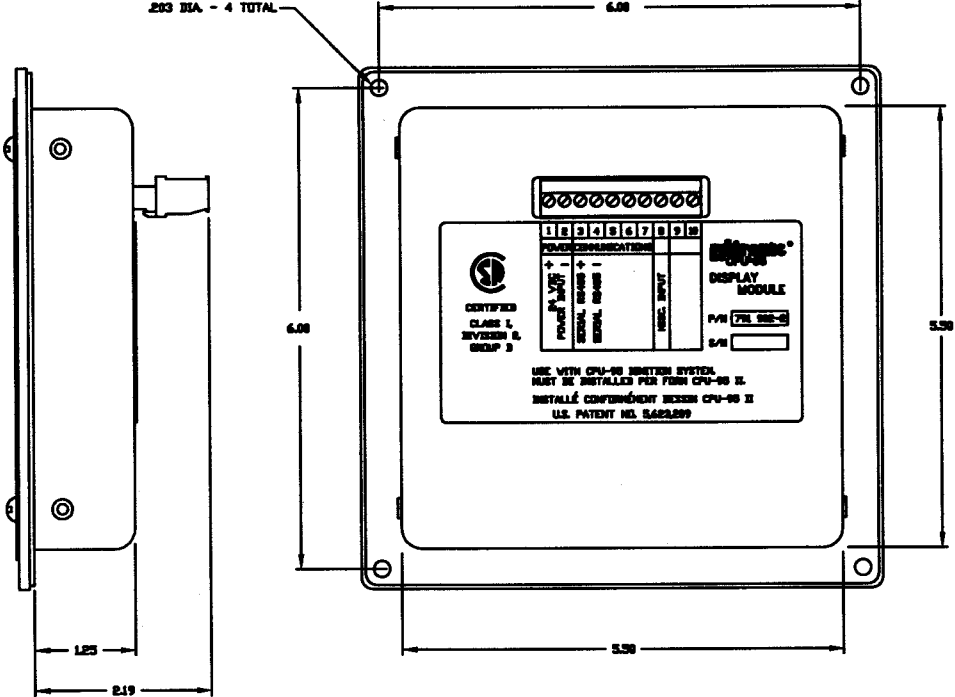
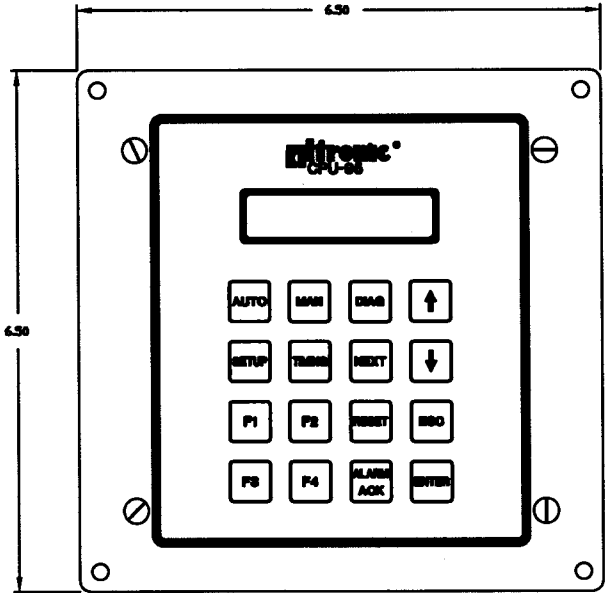

REVISIONS				TELEPHONES	ALTRONIC INC.		
NO.	DATE	BY	DESCRIPTION	COMPANY NO.	TITLE		
1				REG. NO. - 4,888	SALES DRAWING		
2				DATE - 4-88	799-051-2 DISPLAY MODULE		
3				FUNCTIONAL	DESIGN BY	GT	FULL
4					CHECKED BY	DATE	PART NUMBER
5					APPROVED BY	5-12-97	799 051

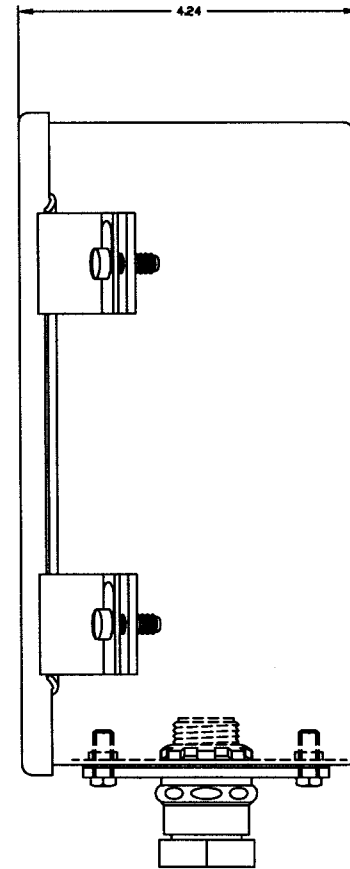
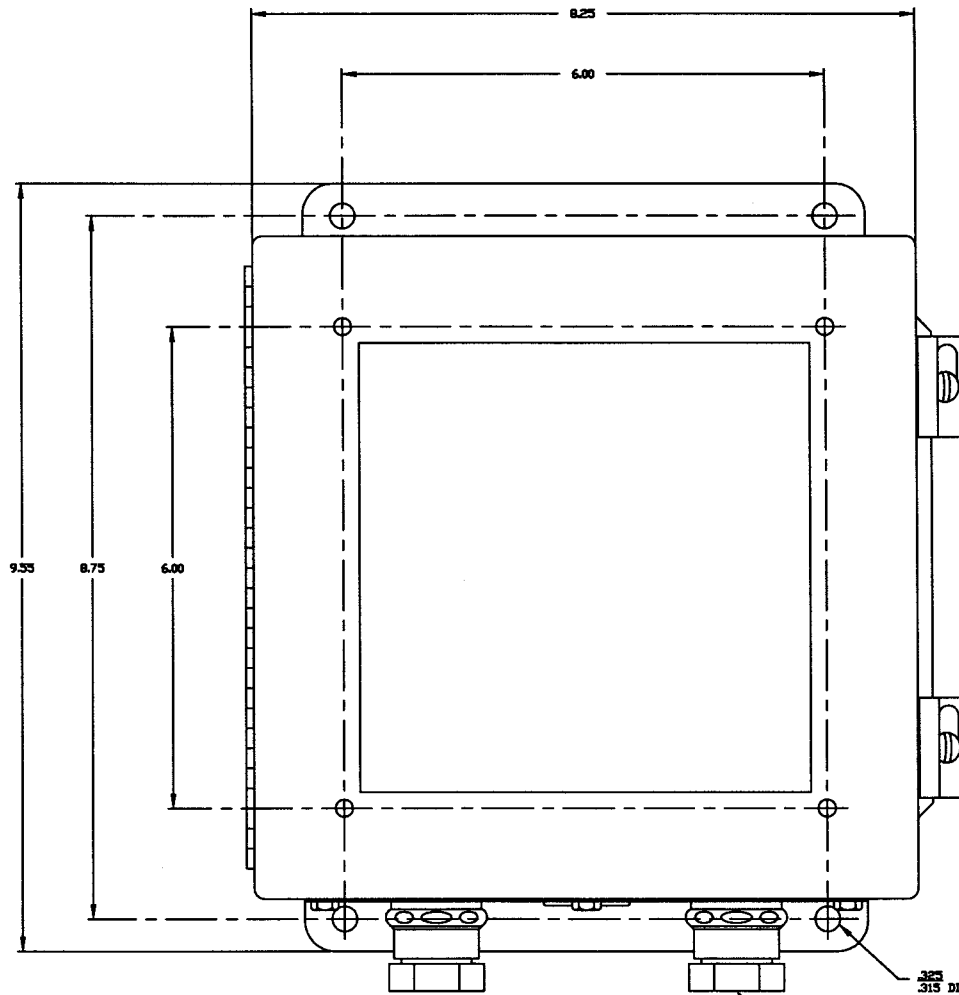

3/8"  
.315 DIA  
(TYP 4)

1/2" CONDUIT FITTINGS (C-H LTB 50)  
TYPICAL 2

799 048

REVISIONS				TOLERANCES (EXCEPT AS NOTED)		ALTRONIC INC.			
NO.	DATE	BY	DESCRIPTION	DECIMAL DIM - 0.005 FIT - 0.004	FRACTIONAL	TITLE		PART NUMBER	
1						SALES DRAWING			
2						NEMA 12 ENCLOSURE			
3						DRAWN BY	GET	SCALE	FULL
4						CHECKED BY		DATE	2-8-96
5						APPROVED BY			799 048